



# Mico Plus



## Baby Capsule

To be used only in rearward facing position until the infant's shoulders reach marker (approx. 6 months of age.)

**IMPORTANT: KEEP THIS BOOKLET IN THE PLACE PROVIDED ON THE CHILD RESTRAINT.**

# Table of Contents

<b>Warranty Information</b> .....	3
<b>Warnings</b> .....	4
<b>Components list</b> .....	8
<b>Vehicle information</b> .....	12
Location of anchor fitting .....	12
Anchorage fitment check .....	13
Upper anchorage installation .....	14
Seat to vehicle positioning .....	17
Vehicle seat location requirements .....	18
Angle configuration for the seat .....	19
<b>Operation and adjustment</b> .....	20
Shoulder height marker .....	20
Preparing infant seat to fit your child .....	21
Removing child from child restraint .....	29
Adjusting handle .....	30
<b>Installation</b> .....	31
Preparing to install base with vehicle belts .....	32
Installing base with vehicle belts .....	33
Two-piece top tether strap fitment .....	35
Removing seat and detaching top tether strap .....	37
Storing tether loop .....	38
Storing instruction manual .....	39
<b>Lower connectors installation</b> .....	40
Preparing to install base with lower connectors .....	41
Installing base with lower connectors .....	42
<b>Aircraft Installation</b> .....	44
<b>Covers and accessories</b> .....	49
<b>Canopy use</b> .....	50
<b>Care and cleaning</b> .....	52
Remove seat cover for cleaning .....	52
Cleaning buckle .....	54
General maintenance .....	56
<b>The next seat for your child</b> .....	57
<b>Guarantee</b> .....	59

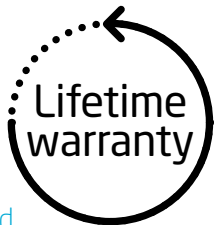

Dear customer,  
**Congratulations** on the purchase of your brand new Maxi-Cosi car seat, we hope you and your little one will have plenty of hours of fun together!

Our car seats are so good, we've put them under a **Lifetime Warranty** – so you can enjoy them for years to come. Don't forget to register within three months after purchase. Go to our website for full terms and conditions.

In the event of a car accident, your Maxi-Cosi child restraint may have unseen damage from crash forces. The **Maxi-Cosi Accident Exchange Service** offers new for old Maxi-Cosi child restraint replacement in the even of a serious accident (where a police report is required), giving you **peace of mind** knowing your child is correctly protected.

## Need assistance?

Call our Customer Service Centre: 1300 809 526  
Monday to Friday (8:30am-5:00pm AEST)  
or send an email: [customerservice@dorel.com.au](mailto:customerservice@dorel.com.au)

[www.maxi-cosi.com.au](http://www.maxi-cosi.com.au)



[maxicosi.australia](https://www.facebook.com/maxicosi.australia)



## WARNINGS

**Read and follow all of the installation instructions for maximum protection. If you have any questions regarding the installation or use of this restraint, please contact Dorel Australia or agent, or a child restraint fitting station authorised by the relevant transport authority, or in New Zealand, to consult the agent for the vehicle.**

### GENERAL

- To be used only in a rearward-facing position until the infant's shoulders reach the shoulder height marker (approximately 6 months of age). Continue to use this infant restraint until the child reaches this limit. Infants are at risk of serious injury if they face forward too early.
- Use the restraint exactly as shown in the instructions.
- Supervision of children is needed because they may be able to undo the buckles.
- **DO NOT LEAVE CHILDREN UNATTENDED IN THE CAR.**
- Do not alter or modify this restraint.
- Repairs must only be done by the manufacturer or agent.
- Do not allow the restraint to come into contact with polishes, oils, bleach and other chemicals.
- Destroy the restraint if it has been in a severe crash, even if no damage is visible.
- **DO NOT USE THIS RESTRAINT WITHOUT THE COVER.**
- To ensure infant's back is evenly supported, do not put more than one nappy on the baby and make sure the nappy is not thickly folded at the back.
- **DO NOT USE A REAR-FACING CHILD RESTRAINT WHERE AN AIRBAG IS FITTED IN FRONT OF THE SEATING POSITION.**
- Fit the restraint firmly to the car seat.
- Fit the harness firmly to the child.



## WARNINGS

- A loose restraint or harness is dangerous.
- Do not harness an infant wrapped in a blanket or swaddled. Any blanket or wrap must only be placed over the harness and infant.
- Care and attention should always be given to ventilation and shading of the child.
- Seatbelt extenders are not recommended to be used if the seatbelt is not long enough to secure the child restraint. If seatbelts are too short then advice should be sought from a child restraint fitter and their recommendations be considered before using a seatbelt extender.
- Always secure the loose end of the top tether strap. Do not use the child restraint where this strap may fall into a split in the seat back or off the side of the seat.
- **ALWAYS ATTACH HOOK AND REMOVE SLACK.**
- THIS RESTRAINT IS NOT SUITABLE FOR USE WHERE THE TOP TETHER STRAP MAY FALL INTO A SPLIT IN THE SEAT BACK OR OFF THE SIDE OF THE SEAT.
- THIS RESTRAINT MUST BE ATTACHED TO A CHILD RESTRAINT UPPER ANCHORAGE POINT IN THE CAR. REFER TO CAR OWNER'S HANDBOOK FOR LOCATION OF UPPER ANCHORAGE POINTS. REFER TO A CHILD RESTRAINT FITTING STATION IF NO UPPER ANCHORAGE POINTS ARE IN THE MOTOR CAR.
- Always check the measurements between the front of the seat back of the rear seat and all front seats in the car in which the child restraint is intended to be used, to ensure that the space is sufficient.
- TO BE USED WITH A LAP-SASH/LAP-ONLY SEATBELT IN THE FRONT/BACK OF MOST CARS WITH FORWARD FACING SEATS.



## WARNINGS

- The use of child restraints in the front seat may be restricted for children of specific ages by local legislation. Please check with your local legislation regarding any restriction for child restraint. If a car has two or more rows of seats, children under four must not travel in the front seat. If all seats, other than the front seats, are being used by children under seven years, children aged between four and six years (inclusive) may travel in the front seat, provided they use an approved child restraint or booster seat.
- Use of aftermarket accessories (i.e. items not provided in the box with the child restraint), can reduce the safety provided by the child restraint and may cause injury or death. For approved aftermarket accessories please refer to page **12**.
- Please contact Dorel Australia Customer Service with any questions or concerns (see page **3** for contact details).



## WARNINGS

For model MAP 2013LA (lower connectors) please note the following additional warnings:

- **TO BE USED WITH A LAP-SASH / LAP-ONLY SEATBELT OR ISOFIX LOW ANCHORAGES IN THE FRONT / BACK OF MOST CARS WITH FORWARD FACING SEATS.**

### IMPORTANT:

- **Do not attach the lower attachment connectors of two separate child restraints to the same ISOFIX low anchorages in your car.**
- **Always attach the top tether strap to the child restraint upper anchorage in your car.**
- **Child restraint lower attachment connectors and the ISOFIX low anchorages in your car are designed to withstand only those loads imposed by a correctly fitted child restraint.**



## WARNING

For model MAP 2013A please note the following additional warning:

- This child restraint is not approved for use with any connectors that connect to the car's ISOFIX low anchorages.

## Components list

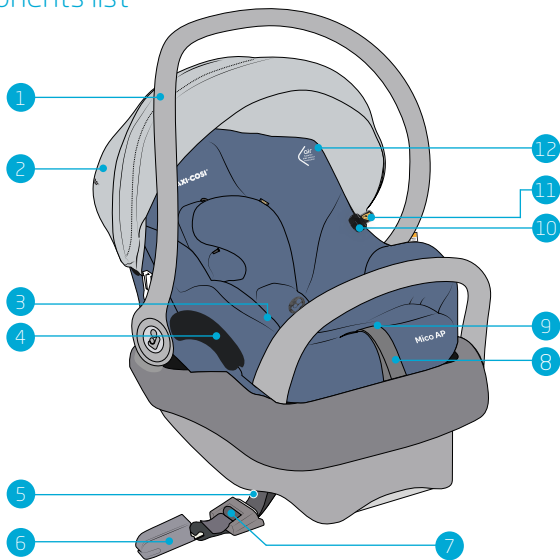

- 
- |  |   |
|--|---|
| 1. Carry handle                                      | 7. Tension adjuster (x2, if fitted)         |
| 2. Canopy  | 8. Harness tightening strap                 |
| 3. Instruction manual storage (under the upholstery) | 9. Harness release lever (under upholstery) |
| 4. Level to Ground Indicator (x2)                    | 10. Stroller release buttons (x2)           |
| 5. Lower connector strap (if fitted)                 | 11. Magnetic harness holders (x2)           |
| 6. Lower connectors (x2, if fitted)                  | 12. Air protect cell (x2)                   |



## Components list

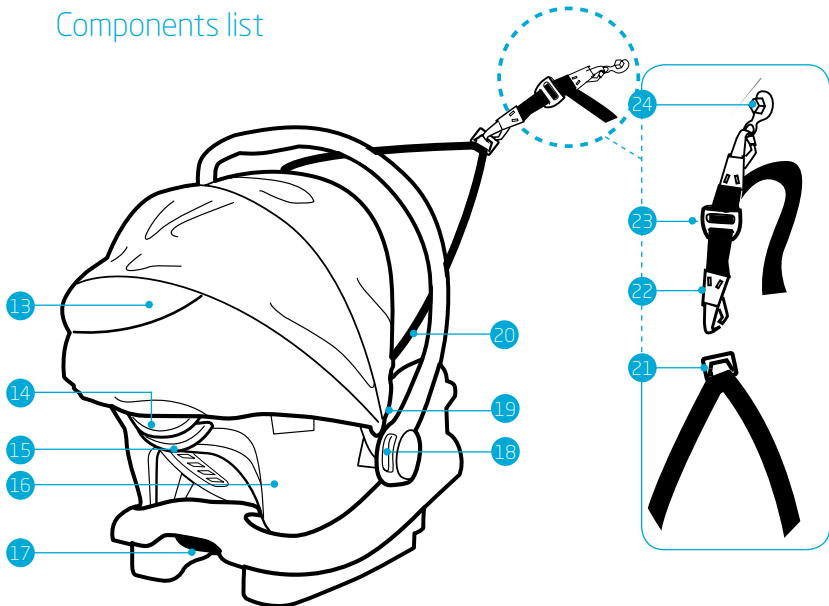

- 13. Canopy window
- 14. Storage pocket
- 15. Seat release lever (behind storage pocket)
- 16. Seat shell
- 17. Base adjustment handle (2 positions)
- 18. Handle adjustment buttons (x2, 3 positions)
- 19. Canopy zip pull

- 20. Loop tether strap
- 21. Top tether metal connector
- 22. Top tether attachment hook
- 23. Top tether adjuster
- 24. Anchor kit

## Components list

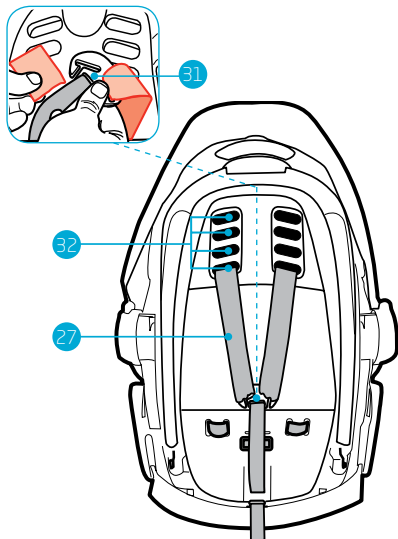
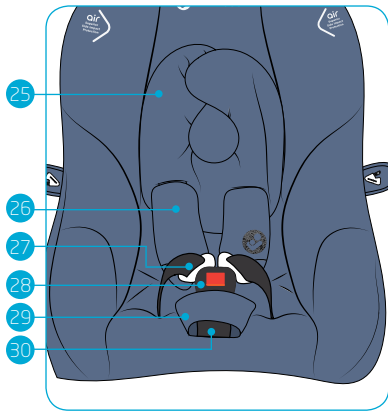

- 25. Infant head insert
- 26. Harness covers (x2)
- 27. Harness straps (x2)
- 28. Buckle
- 29. Buckle cover
- 30. Buckle strap

- 31. Splitter plate
- 32. Harness slots (x8)

## Components list

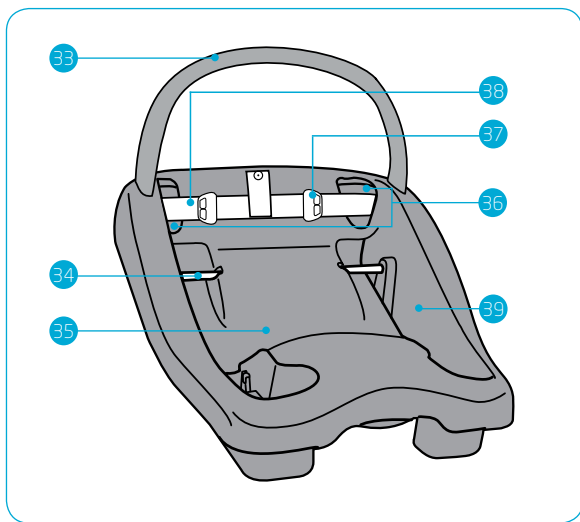

- 33. Stabilising bar
- 34. Locking bar
- 35. Base
- 36. Base belt path opening (x2)
- 37. Tension indicators (x2, if fitted)
- 38. Connector strap (if fitted)
- 39. ISOGO lower connector storage point (located under base x2)

## Vehicle information

### Location of anchor fitting



**POSSIBLE  
ANCHOR  
LOCATIONS**

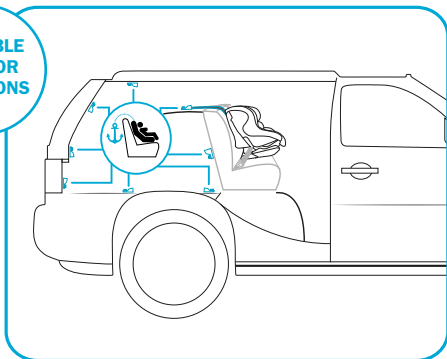

#### **NOTE :**

- The anchor point can be found in different locations in different cars. The illustration above shows possible locations of anchor points. Sometimes it is on the parcel shelf in sedans, and on the floor area in station wagons, vans and hatchbacks. Make sure that you do not confuse the luggage hook in the back of a station wagon with anchor points. Refer to your owner's manual.
- An extension strap may be needed for vehicles without a fixed parcel shelf. Extension straps and extra fittings are available from various stores.

Extension straps 300mm ref no. 014398

Extension straps 600mm ref no. 014399

Anchor bolt kit ref no. 014400



Locking clip ref no. 014401

## Vehicle information

### Anchorage fitment check

Child restraints must be used correctly to provide proper protection for your child. The anchorage system on child restraint must be used in the correct way.

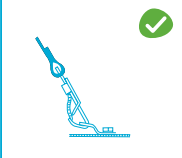
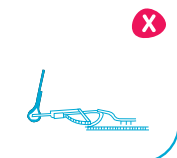

INSTALLATION	CORRECT	INCORRECT
<p><b>Figure 1.</b> Anchorages in vertical panel at rear of vehicle</p>		
<p><b>Figure 2.</b> Floor mounted anchorages</p>		

## Vehicle information

### Upper anchorage installation

#### FOR CARS FITTED WITH A CHILD RESTRAINT UPPER ANCHORAGE POINT

Locate the upper anchorage point behind the rear seating position (consult the car owner's handbook for the location of the upper anchorage point).

Remove the thread plug from the parcel shelf/floor/roof and install the attachment bolt as shown in **Figure 1**.

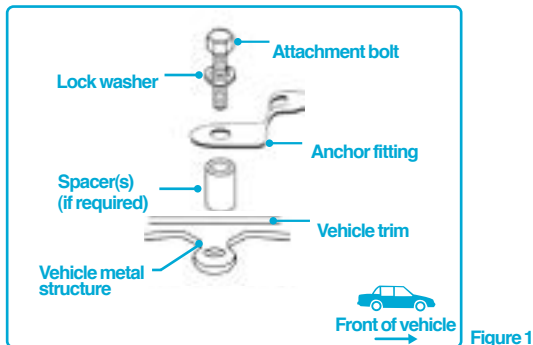

**CAUTION: DO NOT OVERTIGHTEN THE ATTACHMENT BOLT.  
MAXIMUM TORQUE 20 Nm.**

## Vehicle information

Upper anchorage installation for sedans only

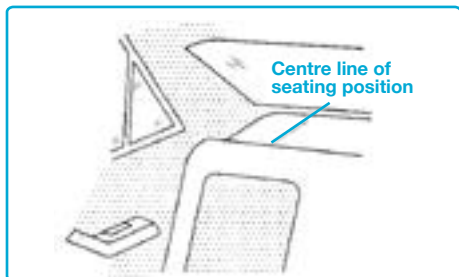

Figure 2

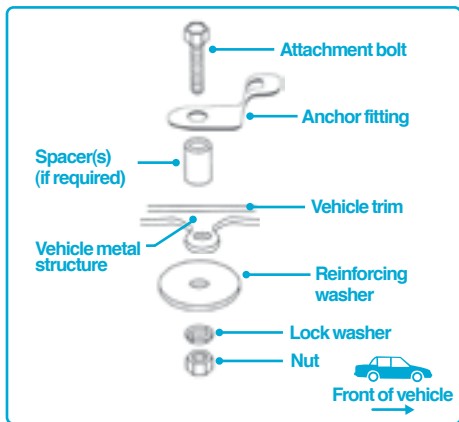

Figure 3

## Vehicle information

### Upper anchorage fitting installation

#### For sedans only

Drill a 9mm diameter hole in the parcel shelf on the centre-line of the seating position as shown in **Figure 2** (as shown on page **15**). Install the anchor bolt as shown in **Figure 3** (as shown on page **15**). It is recommended that this installation be carried out by a child restraint fitting station or licenced motor mechanic.

#### For vehicles other than sedans

In Australia, consult your nearest child restraint fitting station or traffic authority for vehicle inspection to find the best, correct position for the placement of the upper anchorage point, and for the correct attachment bolt length and use of spacers. In New Zealand, consult the agent for the vehicle.



## WARNINGS

**CHILD RESTRAINTS MUST NOT BE ATTACHED TO UNSOUND METAL OR TO WOOD, OR SYNTHETIC STRUCTURES. WHEN DRILLING THE 9mm HOLE DO NOT DRILL THROUGH FUEL LINES, FUEL TANKS, ELECTRICAL WIRING, OR RADIO SPEAKERS. WEBBING STRAPS MUST BE PROTECTED FROM SHARP CORNERS AND EDGES.**

**THE ANCHOR FITTING MUST BE USED ONLY AS DESCRIBED ABOVE. IT MUST NOT BE HOOKED ONTO ANY OTHER OBJECT.**



## Vehicle information

### Seat to vehicle positioning

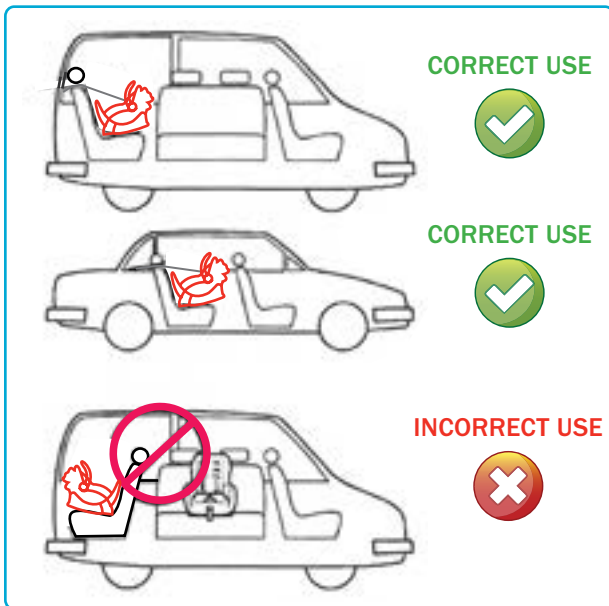

## Vehicle information

### Vehicle seat location requirements

Some seating positions in your vehicle may **NOT** be safe for this safety seat. Some vehicles do not have any seating positions that can be used safely with the seat. If you are not sure where to place the infant seat in your vehicle, consult your vehicle's owner's handbook.

#### Vehicle seat location requirements:

Children are safer when properly restrained in rear vehicle seating positions. Whenever possible, secure the infant seat in the centre position of the seat directly behind the front seats.

### **WARNING**

- **IMPROPER PLACEMENT OF THE SAFETY SEAT INCREASES THE RISK OF SERIOUS INJURY OR DEATH.**

**NOTE:** Check the measurements between the front of the seat back of the rear seat and all front seats in the car in which the child restraint is intended to be used, to ensure that the space is sufficient.

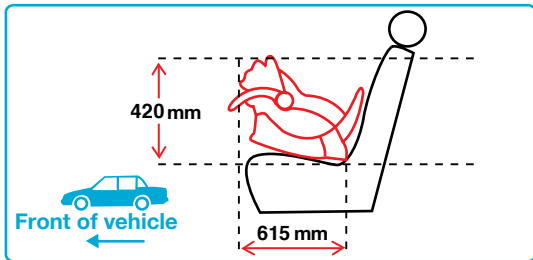

## Vehicle information

### Angle configuration for the seat

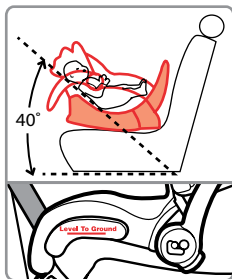

- Position seat ensuring that the angle is no greater than  $40^\circ$  from horizontal plane. This position is necessary for the even distribution of forces during possible impact.
- Angular adjustment is achieved by adjusting the base. Make sure the line indicator is level to ground (refer to page 21).



## WARNINGS

- **DO NOT** install convertible child restraints excessively reclined, ensure the angle is no greater than  $40^\circ$ .
- **DO NOT** adjust harness or tether strap hardware such that it sits too close to the occupant.
- Ensure that correct seatbelt path is used and that the restraint is installed in the correct direction for rearward-facing application. Refer to page 31.
- **DO NOT** wrap baby in a blanket or swaddled as infant can be ejected and killed in an accident.
- Ensure the harness fits the baby firmly.
- Ensure that any blanket or other covering may only be placed over the harness after the harness is adjusted firmly.
- The infant's legs and arms are not to be bound or wrapped together.
- Always adjust the height of the shoulder straps as the child grows.

## Operation and adjustment

### Shoulder height marker

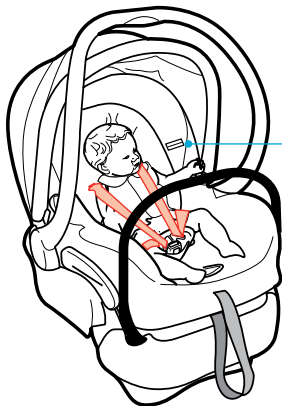

LABEL 1

SHOULDERS MUST BE



BELOW THIS LINE

The child restraint is not suitable for the child when the child's shoulders are above the shoulder height marker.



## WARNINGS

- To be used only in a rearward-facing position until the infant's shoulders reach the shoulder height marker (approximately 6 months of age).
- Continue to use this infant restraint until the child reaches this limit. Infants are at risk of serious injury if they face forward too early. For information regarding the next seat for your child, refer to page 57.
- The child restraint is not suitable for the child when the child's shoulders are above the shoulder height marker.

**NOTE: If the baby's neck muscles are unable to support their head, then the child should remain rear facing.**

## Operation and adjustment

Preparing infant seat to fit your child

**NOTE:** You **MUST** make these adjustments before you install the child restraint in the vehicle.

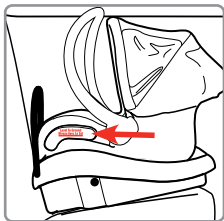

- Place the child restraint in the car and see if seat is level to ground.

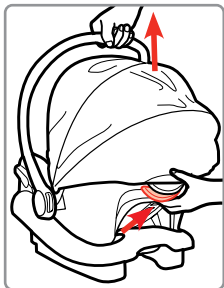

- If the base needs adjusting, remove the seat from the base by squeezing the seat release lever, then lift the seat up and off the base.

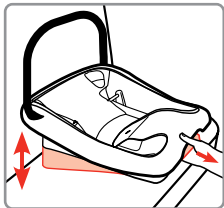

- Squeeze the base adjustment handle and either lift or lower front of base to the desired position.

## Operation and adjustment

Preparing infant seat to fit your child (cont'd)

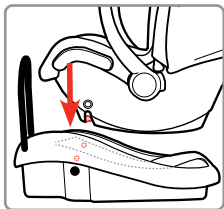

- Align the slots on the side of child restraint with the locking bars in the base.
- Push down firmly on the carrying handle and front of the child restraint will lock to the base.

LISTEN FOR CLICK.

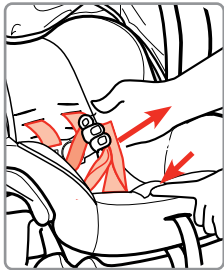

- To loosen harness, push down and hold on the harness release lever (under flap - see page 8).
- Pull on one harness strap or both harness straps simultaneously while pressing down on **the harness release lever**.

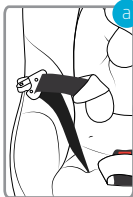
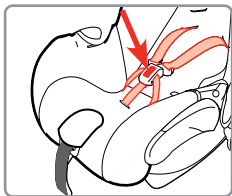

- Press red button to undo buckle.
- Pull buckle tongues out.
- Stretch belt tongues to magnetic holders on the left and right side of the capsule, to snap them into place (**figure a**).

## Operation and adjustment

Preparing infant seat to fit your child (cont'd)

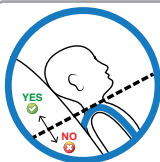
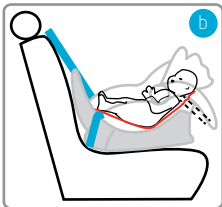

Check harness height. The shoulder straps must be in the slots which are nearest to the child's shoulders, but not lower than the child's shoulders.



- Child should be in rearward position as shown in **figure b**.
- Place the child's bottom and back flat against the child restraint. This will increase comfort and allow the harness straps to be properly tightened.

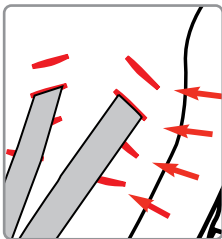

- To change the harness height, determine which set of harness slots works best for your child and adjust if needed.
- Always adjust the height of the shoulder straps as the child grows.

## Operation and adjustment

Preparing infant seat to fit your child (cont'd)

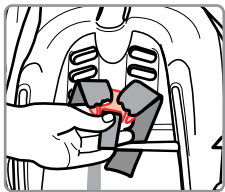

- If harness adjustment is required, locate splitter plate at rear of seat.

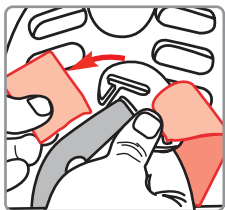

- Remove harness straps from splitter plate at rear of seat.
- Pull harness through the harness slots from the front.

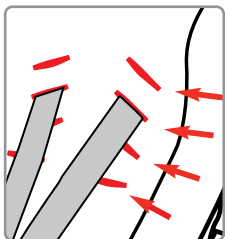

- Re-thread harness into new harness guide locations.

**NOTE:** Do **NOT** use shoulder straps of unequal heights. Straps must be threaded through the same slot level for the trim and seat.



## Operation and adjustment

### Preparing infant seat to fit your child (cont'd)

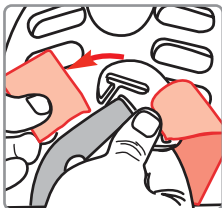

- Refit harness to splitter plate.

**NOTE:** Make sure harness is securely on and there are no twists.

- Place child in the restraint and position harness straps over the child's shoulders.

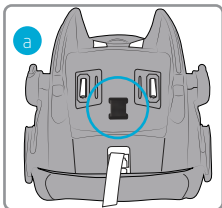

### Crotch buckle adjustment

- The carrier is supplied with the buckle length in its shortened state, which is suitable for smaller children.
- To extend, flip carrier over to expose the underside and subsequent straps. They should appear as shown in figures **a** and **b**.

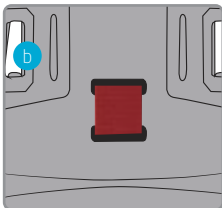

## Operation and adjustment

### Preparing infant seat to fit your child (cont'd)

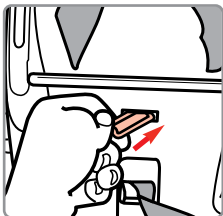

- From under the upholstery, turn and slide buckle's metal retainer back through the shell, extending the buckle's length.

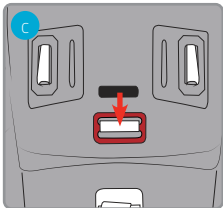

- The metal retainer should now intersect with the under surface of the shell (as show in **figure c**).

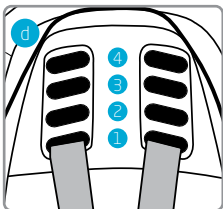

- From other side, pull on buckle to check to make sure buckle's metal retainer is correctly inserted through the trim and shell.

**NOTE:** It is recommended the buckle be extended when the child's shoulder's reach harness slots, 3 or 4 as show in **figure d**.

## Operation and adjustment

Preparing infant seat to fit your child (cont'd)



- To tighten the harness, fasten buckle and listen for the click when the second tongue goes in.

**NOTE:** When using the buckle please note that you will not hear a click when the first tongue goes in, it is only on the second tongue.

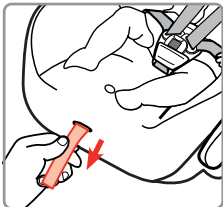

- Pull the adjustment strap at the front of the seat until the harness belt lies firmly against the child.



**WARNING**

- **DO NOT LEAVE CHILDREN UNATTENDED IN THE CAR.**

## Operation and adjustment

Preparing infant seat to fit your child (cont'd)

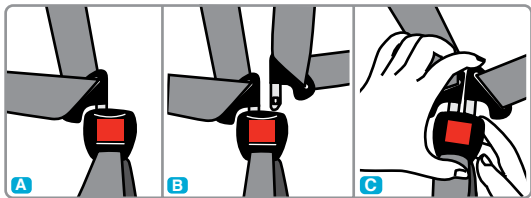

- A** Insert one buckle tongue as shown above.
- B** Insert the second buckle tongue as illustrated above.
- C** Press both tongues simultaneously. Listen for click.

**NOTE:** Remember to always pull up on the harness straps to make sure buckle is locked. Click will sound when both clips are engaged.

## Operation and adjustment

### Preparing infant seat to fit your child (cont'd)

**NOTE:** A firm strap should not allow any slack. It lies in a relatively straight line without sagging. It does not press on the child's flesh or push the child's body into an unnatural position.

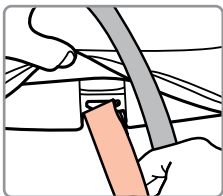

- The end of the harness adjustment strap has a loop. Slide one side of the loop onto one tab and the other end on the other tab.
- Replace the trim cover over the front of the shell.

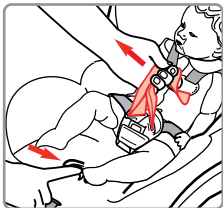

### Removing child from child restraint

- To loosen, push down on the harness release lever (under flap on the front of child restraint), while pulling on both harness straps above the buckle.

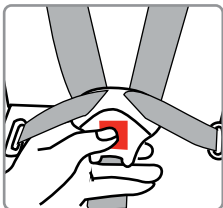

- To unbuckle, press red button on buckle to release the buckle tongues.
- Stretch belt tongues to magnetic holders on the left and right side of the capsule, to snap them into place.

## Operation and adjustment

### Adjusting handle

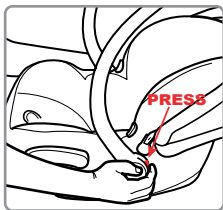

- The carrying handle has 3 positions. To adjust handle, press both adjustment levers on each side of handle. Rotate up or down to desired location.
- Release levers. Listen for click.
- Make sure both sides are locked into place.

#### CAR / CARRY POSITION



**A**



**B**

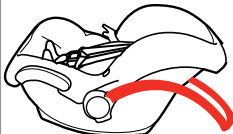

**C**



## REARWARD FACING BELT PATH

REARWARD-FACING (Newborn to 6 months)

### OPTION 1 LAP SASH BELT PATH

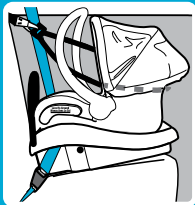

### OPTION 2 LAP BELT PATH

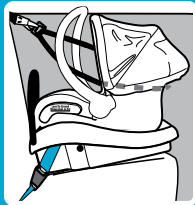

**NOTE:** There is an option to install seat using a seatbelt with an accessory locking clip. Please see instructions provided with locking clip for installation.

## Installation

### Lap sash and lap base installation



#### PREPARING TO INSTALL BASE WITH VEHICLE BELTS

### WARNINGS

- Do not use the lower connectors along with the vehicle lap or lap/shoulder belt. Store lower connector strap when using the vehicle belts.
- Check the vehicle belt before each use. Use only if the belt is tightened properly and securely.
- Failure to follow these warnings can result in serious injury or death.
- Failure to securely attach child restraint to base can result in serious injury or death.

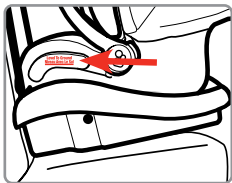

- Using level to ground line as a guide, select the base recline which is best suited for your vehicle. Refer to page 21 for base adjustment.

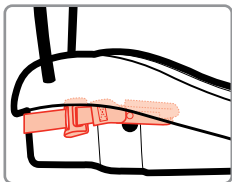

#### IF FITTED WITH LOWER CONNECTORS:

- You **MUST** store the lower connector strap when using the vehicle seat belts. Store strap by connecting the lower connectors to side of base as shown.



## Installation

### Lap sash and lap base installation



#### INSTALLING BASE WITH VEHICLE BELTS

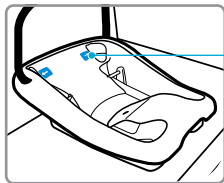

#### REARWARD FACING BELT PATH

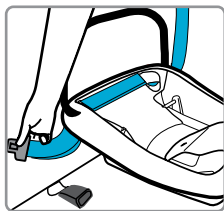

- Install base facing backwards, with the stabilising bar against the back of the car seat.
- Thread the vehicle lap or lap/shoulder belt combination through belt path as shown.
- Thread the vehicle lap or lap/shoulder belt combination through belt path as shown.

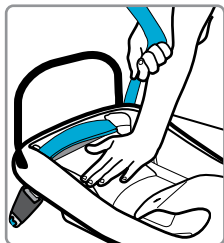

- Buckle vehicle belt. Push down firmly on the base and pull up on the belt to tighten. Pull up on shoulder strap to remove any slack.

## Installation

### Lap sash and lap base installation

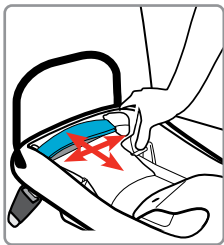

- With weakest hand at belt path, tilt and push the base forward and back, and from side to side.
- If the seat belts do not loosen, your child restraint should be secure.

**NOTE:** Some movement from front to back or from side to side is acceptable.

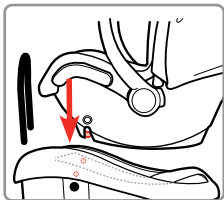

- With child secured in child restraint, attach to base.
- Align the slots on the side of child restraint with the locking bars in the base.
- Push down firmly on the carrying handle and the front of the child restraint to lock child restraint to base. You will hear a **click** when it is locked.
- Pull up on child restraint's front two corners to make sure the front of the child restraint is locked to the base.

 **TOP TETHER INSTALLATION**  
REARWARD-FACING (Newborn to 6 months)

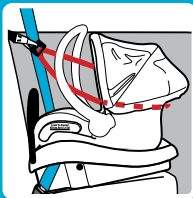

## Installation

### Two-piece top tether strap fitment

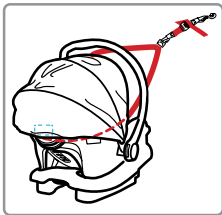

- Attach the hook to anchor in vehicle.
- Adjust tether strap to remove slack in strap (Pull on free end of webbing to tighten).
- Make sure the base is not lifted from the car seat.

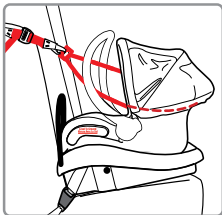

**NOTE:** Do not use canopy extension feature during vehicle operation or when top tether is in use.

**CAUTION:** CHILDREN CAN BE INJURED OR RESTRAINTS AND TOP TETHER STRAP DAMAGED BY UNSECURED CARGO IN A COLLISION. SECURE OR REMOVE HAZARDOUS CARGO BEFORE USING THIS CHILD RESTRAINT.



## WARNINGS

- Always secure the loose end of the top tether strap to prevent it hanging out of the car or being accessible by the child.
- When not in use, fold hanging tether strap and place in the storage pocket provided.

## Installation

### Removing seat and detaching top tether strap

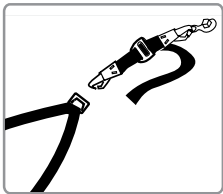

- Loosen the top tether strap using the adjuster and unhook the top tether strap from the loop section.
- Leave the tether attached to the anchor point in car.

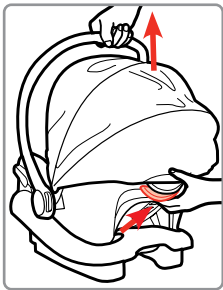

- From the back of the child restraint, slide the base release handle up the back of the child restraint and lift the restraint out of the base.

**NOTE:** When not in use, fold top tether strap and place in the storage pocket provided.

## Installation

### Storing tether strap

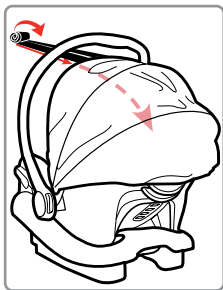

- After detaching the top tether strap, roll the loop tether strap back towards the child restraint, and store it in the storage pocket located at the rear of the shell.

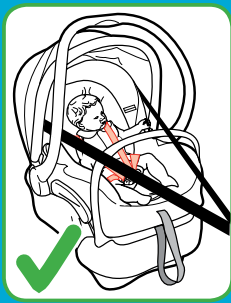
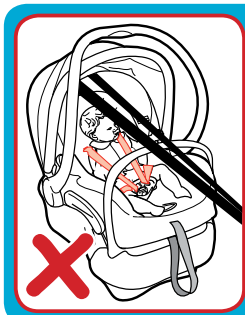

When removing the loop tether strap from the storage pocket, **DO NOT** pull the strap directly across the child restraint. Instead, be sure to evenly spread the loop tether around the side, in line with the shoulder height markers.

## Installation

### Storing instruction manual

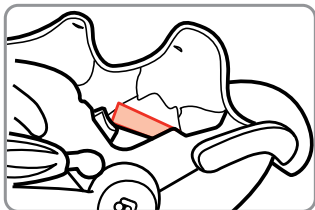
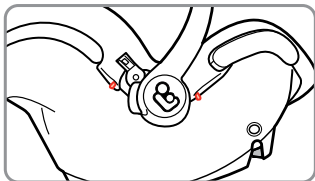

- Unhook the cover from the two pins moulded onto the seat as shown, then repeat for alternative side.
- Unfold the trim from the front of the capsule, folding it towards the back, exposing the buckle strap.
- Place instruction manual in the plastic pocket provided. Then slide both under the trim in front of the buckle.
- Re-attach the trim in reverse order once instruction manual is stored.

## Lower connectors installation

(if fitted)

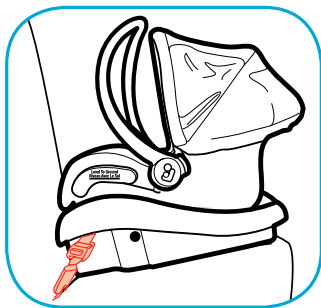

LOOK FOR THESE SYMBOLS FOR  
ATTACHMENT IN VEHICLE



ISOFIX



### WARNINGS

- **Never place a child rear-facing in a seating position with an active frontal airbag. This can result in serious injury or death.**
- **This child restraint must always face the rear of the vehicle when installed.**



## Lower connectors installation

(if fitted)



### PREPARING TO INSTALL BASE WITH LOWER CONNECTORS

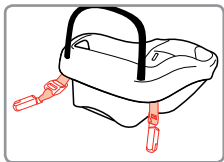

- Unhook lower connectors on both the right and left side of the base by pressing the red release button on each connector.

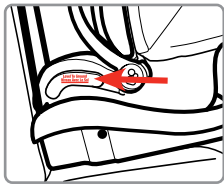

- Using level to ground line as a guide, select the base recline which is best suited for your vehicle. Refer to page 21 for base adjustment.

## Lower connectors installation

(if fitted)



### PREPARING TO INSTALL BASE WITH LOWER CONNECTORS

See your vehicle owner's manual for information on designated lower connector positions, anchor locations and anchor weights.

## WARNINGS

- **Do not use the lower connectors along with the vehicle lap or lap/shoulder belt.**
- **Check lower connector strap before each use. Use only if the strap can be tightened properly and securely.**
- **Failure to follow these warnings can result in serious injury or death.**

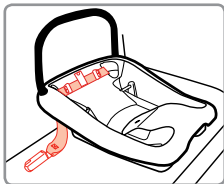

- Centre the base between the vehicle anchors in the chosen seating position.

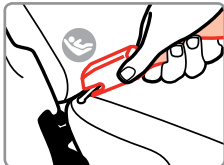

- Fasten one lower connector to the anchor in the vehicle seat located in the recess of the upholstery. Repeat for the other side of base.

## Lower connectors installation

(if fitted)



- Push down firmly on the base and pull up on the free end of belt to tighten. The tension indicator will display green when tight.
- **Grasp the base at the belt path** with one hand. Push and pull the base from side to side, forward and back. The base should be locked into a firm, snug fit with little movement.



**NOTE:** Some movement from front to back or from side to side is acceptable.

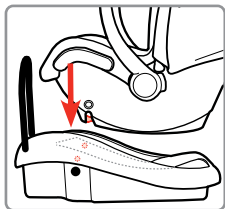

- With child secured in child restraint, attach to base.
- Align the slots on the side of child restraint with the locking bars in the base.
- Push down firmly on the carrying handle and the front of the child restraint to lock child restraint to base. You will hear a click when it is locked.
- Pull up on child restraint's front two corners to make sure the front of the child restraint is locked to the base.
- Attach top tether strap (page 35).



## AIRCRAFT INSTALLATION



This Child Restraint System meets the standards for use in aircraft as recommended by the Civil Aviation Safety Authority of Australia and Civil Aviation Authority of New Zealand.

Only to be used on aircraft with permission of the aircraft operator, pilot and crew.

### **SUITABLE FOR REAR FACING USE**

The top tether strap is not required to be used onboard aircraft and should be stowed securely.

This compliance label represents the products suitability for installation into an aircraft using a rearward facing position.



### **Please note before installation**

- Never use this belt path in a car.
- Child restraint must be used in accordance with the air craft procedures and any directions from crew.
- Inform air craft operator that a child restraint intends to be used as they may not be suitable for specific air crafts.
- The infant carrier may not fit in smaller air crafts.
- If the use of carrier is intended for the use in countries other than AUS and NZS, consult with local authorities, car hire companies, car insurance companies etc. for advice. The child restraint may not be acceptable for use in all cars.
- Infant carrier to be installed without base. It is recommended it be checked in with baggage (for use after flight).
- The child restraint's top tether strap is not required when used on board an air craft.
- Do not use this restraint with an aircraft seat belt that contain air bags. The aircraft operator may replace them.

## Aircraft installation

### Fitting the carrier to the aircraft seat



As the top tether is not required in this installation process, please refer to page 38 for instructions on how to store your top tether strap.

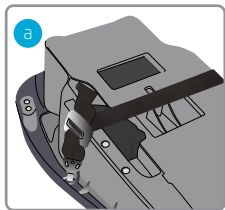

- Remove top tether extension from car and clip each end onto the ISOGO lower connector storage points as shown in (figure a).
- Tighten top tether strap (as detailed on page 36) so that the connecting strap is firm to the base.
- Tighten ISOGO lower connectors (as detailed on page 43) until the belt path is exhausted.
- Position the carrier rearward facing. Ensure the carrier is aligned centrally with the seat position. Folding the arm rests upwards could facilitate the installation of your carrier.
- Pull back cover on the side (figure b), to reveal **AIRCRAFT SEATBELT PATH** label marked in green.

Note: Never use this path in a car.

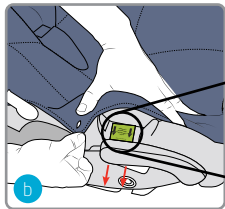

## Aircraft installation

### Fitting the carrier to the aircraft seat

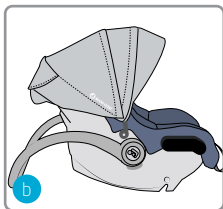

- Ensure handle is placed in the “non-rocking” position (**figure b**). Refer to page **30** for a detailed explanation regarding this function.
- Lengthen the lap belt to full capacity (it may be necessary to use an extension strap to better position the aircraft buckle). Make sure the belts are not twisted.

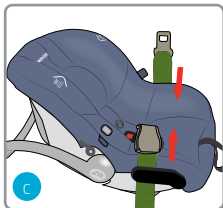

- Feed the lap belt into the **AIRCRAFT REARWARD-FACING BELT PATH** ensuring the lap part is threaded through the belt path as shown (**figure c**), on each side. Engage lap belt buckle and tongue.

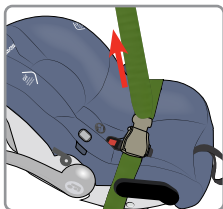

- To fasten belt and secure capsule, press down on the carrier firmly and pull aircraft belt strap to tighten. Ensure the capsule is fastened correctly and firmly.

## Aircraft installation

Fitting the carrier to the air craft seat

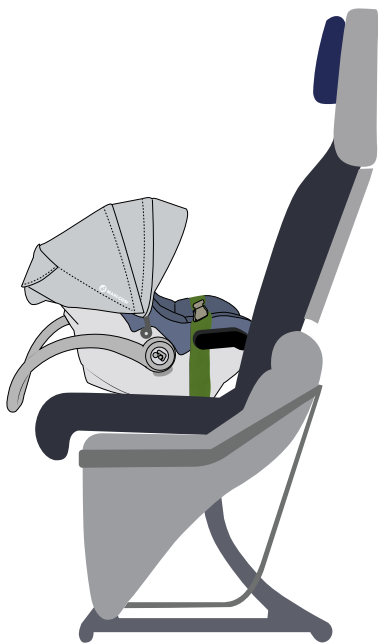
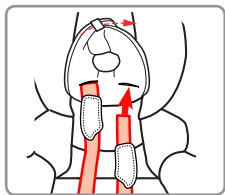

Image represents final state of installation



## Covers and accessories



**NOTE:** Before fitting covers, remove harness from splitter plate (see page 24).

- Thread harness straps through the harness pads.
- Place infant head insert over harness slots, aligned with the appropriate slot for your child's shoulder height (see page 23).

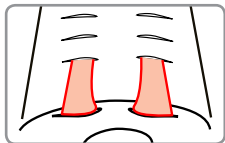

- Fit end of infant head insert through band on other side, securing the loop.
- Thread harness straps through slots on infant head insert, and continue through harness slots on capsule.

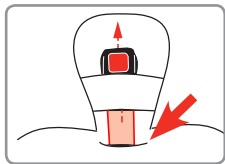

- Thread harness buckle through buckle cover, ensuring that the largest side is facing the child's crotch.
- Tuck end of buckle cover in through buckle slot, securing the cover in place.

**NOTE:** Refit splitter plate before continuing (see page 25).

## Canopy use

### Installation and removal of canopy

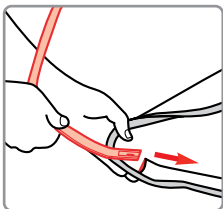

- The canopy hoop has an angle that will make the canopy lean forward when installed. Make sure when you thread the canopy hoop, the angle is correct.
- Thread plastic strip completely through channel on the front edge of canopy
- Snap each plastic strip end to each canopy post.
- Fit back of canopy over back of shell.
- Thread canopy hoop through canopy elastic loop.
- Stretch canopy loops over canopy posts.

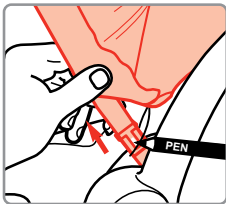
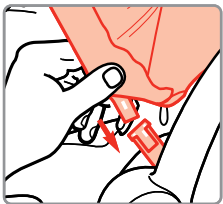

- **To remove canopy:** Use a pen or any pointed object to push the small tab as illustrated and simultaneously pull the plastic strip.

## Canopy use

### Canopy hood extension

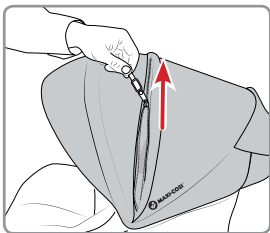

- Unzip canopy to full extent.
- Pull forward canopy extension visor towards the front of the capsule until the magnet fasteners snap into place (**figure a**).

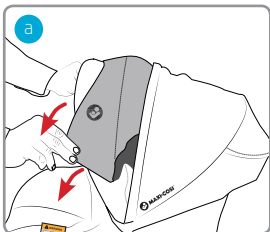

- For increased airflow, raise the canopy window at rear of capsule (**figure b**).

**NOTE:** Canopy extension **MUST** not be used when vehicle is in operation.

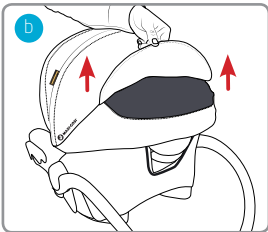
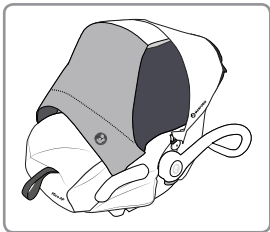

## Care and cleaning

Remove seat cover for cleaning

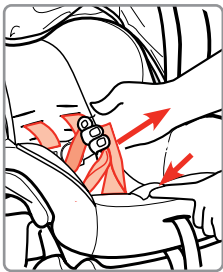

- Push down and hold on the on the harness release lever (under flap - see page 8).
- Pull on one harness strap or both harness straps simultaneously.

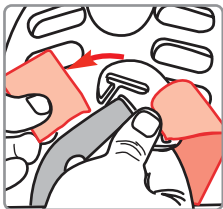

- Remove harness straps from splitter plate at rear of seat.

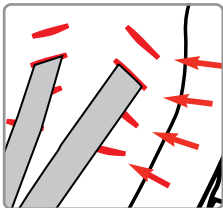

- From the front, pull harness straps out of the shell and trim. Remove the shoulder pads and insert.

## Care and cleaning

Remove seat cover for cleaning

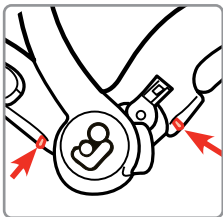

- Unhook the cover from the two pins moulded onto the seat as shown. Repeat for alternative side.



- Unfold the trim from the back of the capsule, folding it towards the front, peeling it away until completely removed.

### **VERY IMPORTANT:**

**Only replace the cover with a manufacturer's supplied replacement cover with identical shoulder height markers or a replacement cover meeting AS/NZ 8005.**

## Care and cleaning

### Cleaning buckle

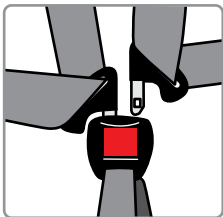

- Push red button to release the buckle.
- From under seat shell, turn and slide buckle's metal retainer up through the shell and trim, removing the buckle.

**NOTE:** For cleaning instructions, see page 55.

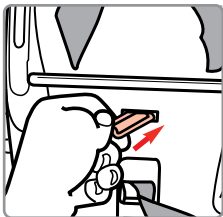

- To assemble, ensure that the red button on the buckle is facing out. Push metal retainer clip through trim and shell.

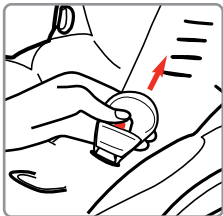

- From other side, pull on buckle to check to make sure buckle's metal retainer is correctly inserted through the trim and shell.

## Care and cleaning

### Cleaning buckle

Follow the manufacturer's instructions at all times. Before removal, ensure you have carefully noted the way which the various parts are attached to the seat so as to facilitate reassembly.

Your child restraint is equipped with a buckle designed to give your child maximum protection during proper use. When working properly, your buckle should always fasten with an audible **click**.

If sticky liquids (such as baby food, fruit juice, etc.) get into the buckle it may become sluggish and you may not hear a **click**.

The buckle should be cleaned by following the steps below.

#### CLEANING BUCKLES

- Place the buckle unit under running water (40 degrees Celsius). Let the water flow through the mouth of the buckle for one minute.
- Immediately latch and unlatch the tongues into the buckle several times until a strong audible click is heard.
- **Do not** oil any part of the buckle.
- Allow buckle to dry.
- If the buckle does not work, contact Dorel Australia Customer Service on 1300 809 526

## Care and cleaning

### General maintenance

- All other surface should be cleaned with a mild soap and water.
- Never clean with ammonia or bleach based, or spirit-type cleaners.
- Clean the frame with a damp cloth.
- Do not use the restraint without the cover.
- Check the webbing for fraying.
- Ensure there are no cracks in moulding or the plastic moulding.
- Check the Harness Adjuster is operating and is clamping the webbing.
- If any part of the restraint is cracked or broken, seek repair immediately or replace the child restraint.



## The next seat for your child

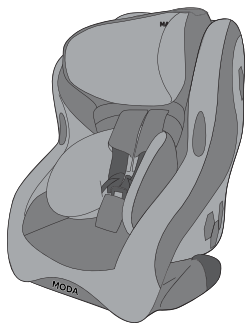

### **OPTION 1: TYPE A4/B CONVERTIBLE CAR SEAT**

To be used only in a rearward-facing position until the infant's shoulders reach the lower shoulder height marker (approximately 12 months of age) or reach the middle height marker (approximately 2-3 years of age).

Then to be used in a forward-facing position until the child's shoulders reach the upper shoulder height marker (approximately 4 years of age).



## Guarantee

Dorel Australia Pty Ltd warrants your new product to be free from defects in materials and workmanship for 10 years on the seat & 3 years on the trim, from the date of purchase, provided that the product is used in accordance with accompanying recommendations or instructions where provided. The benefit of this warranty is in addition to your rights under the Australian Consumer Law and to other rights and remedies of the consumer under a law in relation to the goods or services to which the warranty relates.

Dorel Australia Pty Ltd will provide you with your choice of a refund, repair, or exchange (where possible) for this product if it becomes defective within the warranty period. Dorel Australia Pty Ltd will bear the reasonable expense of claiming the warranty. This warranty will no longer apply where the defect is a result of alteration, accident, misuse, abuse, or neglect.

Please retain your receipt as proof of purchase and contact our Customer Service team on Ph: **1300 809 526** or alternatively, via our website at **www.dorel.com.au** for any difficulties with your product. Warranty claims and claims for expense incurred in returning this product can be addressed to our Consumer Service team at **655-685 Somerville Road, Sunshine West, VIC, 3020**. Hours: 8:30 am to 5:00 pm, Monday to Friday.

For New Zealand please contact Customer Service Centre, **14 Sir William Avenue, East Tamaki, Auckland, 2013**. Auckland: **(09) 2741040** NZ wide: **0800 628 000** (Toll Free). Hours: 8:00 am - 5:00 pm, Monday to Friday.

Our goods come with guarantees that cannot be excluded under the Australian Consumer Law. You are entitled to a replacement or refund for a major failure and compensation for any other reasonably foreseeable loss or damage. You are also entitled to have the goods repaired or replaced if the goods fail to be of acceptable quality and the failure does not amount to a major failure.

**IMPORTANT: KEEP THIS INSTRUCTION MANUAL IN THE POCKET PROVIDED ON THE HEADREST.**



Dear Customer,  
Don't forget to register your product  
within 3 months of purchase for  
the Lifetime Warranty offer.\*

Please visit to register now.

[www.maxi-cosi.com.au](http://www.maxi-cosi.com.au)



© 2017 Dorel Australia, Pty Ltd. All Rights Reserved.  
MAP 2013A, MAP 2013LA #017767 08/2017

\*Terms and conditions apply.  
Please visit our website to find out more.

