

FITTING KIT COMPONENTS

- 2 X CASTORS
- 10 X JCB BOLTS (M6 X 100MM)
- 2 X ALLEN KEYS
- 2 X MOULDING WITH NO PIN
- 1 X SPACER (LARGE WASHER) IF REQUIRED
- 6 X CONNECTOR BOLTS (M6 X 60) AND CAPS
- 2 X ELECTRO BRASS M6 X 20 BOLT

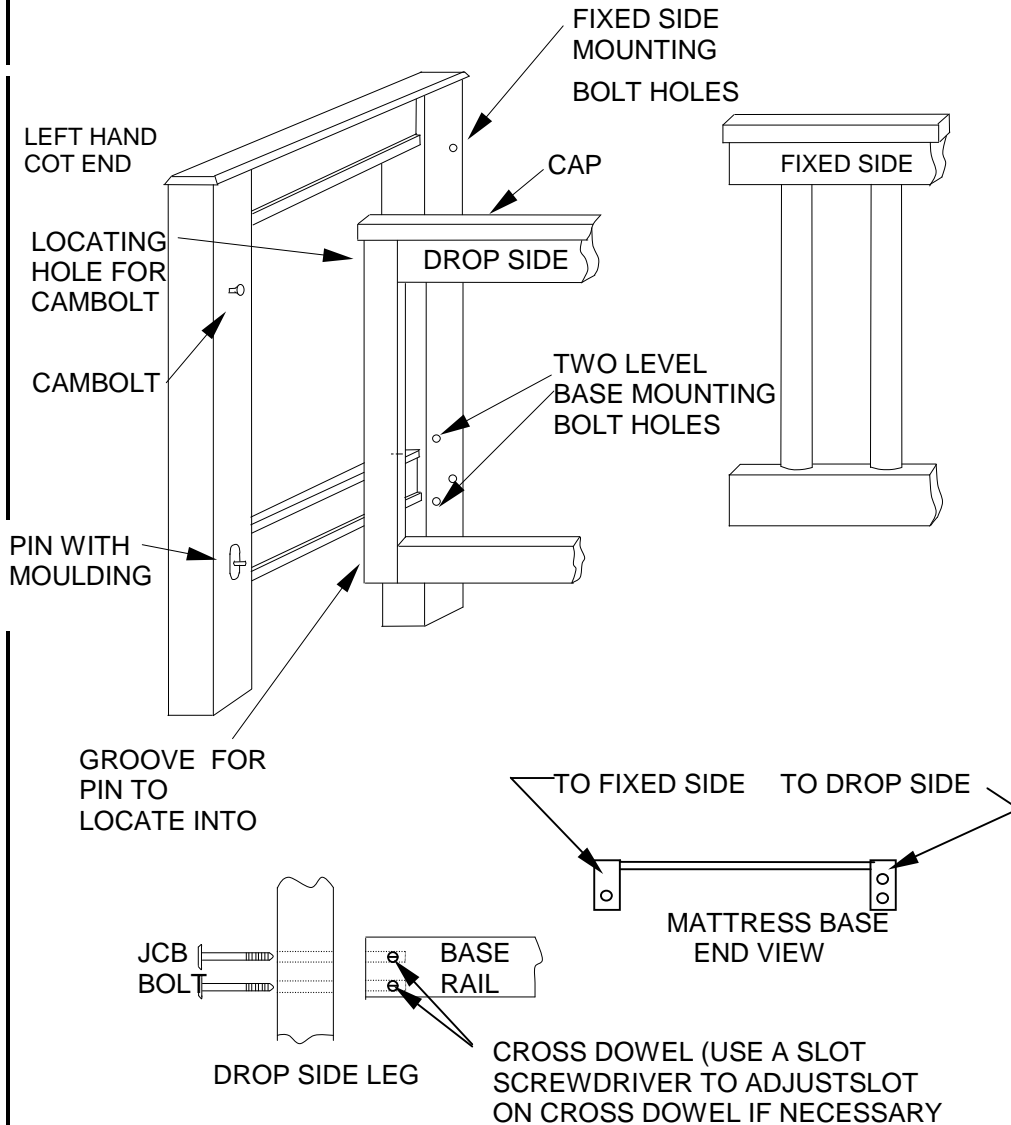

ASSEMBLY OPTIONS

- OPTION 1 WITH BASE IN HIGH POSITION.** THIS IS FOR USE WHEN YOUR BABY IS YOUNG AND CANNOT SIT UP. THE BASE IS AT A CONVENIENT HEIGHT TO USE AS A CHANGING TABLE WITH THE DROPSIDE DOWN AND IT IS MUCH EASIER TO TUCK BABY IN WITHOUT HAVING TO BEND UNNECESSARILY.
- OPTION 2 WITH THE BASE IN THE LOW POSITION.** THIS IS THE NORMAL POSITION FOR ACTIVE BABY (RE: **WARNING**).
- OPTION 3 TO CHANGE COT INTO A BED.** SIMPLY DISMANTLE AND REASSEMBLE COT USING SHORT BED END. THE BASE RAIL IS BOLTED TO THE SHORT BED END (FOOT END), AND TO THE HEADBOARD END (THE END WITHOUT ANY CASTORS). SHORT BED END IS AN OPTIONAL EXTRA ITEM. REMOVE CAM-BOLT AND PIN WHEN USING AS A BED. THE MOULDING WITH PIN CAN BE REPLACED WITH THE ONE WITHOUT AND THE M6 X 20 BOLTS CAN BE USED IN PLACE OF THE CAM-BOLTS TO PLUG UP THE HOLES.

IT IS IMPORTANT TO FOLLOW THE MANUFACTURER'S ASSEMBLY INSTRUCTIONS IN DETAIL TO ENSURE THE SAFETY FEATURES OF THE COT ARE NOT COMPROMISED

ASSEMBLY INSTRUCTIONS

1. IDENTIFY ALL PARTS AND COMPONENTS (**AS PER DIAGRAM**)
 2. ATTACH LOCKING CASTORS TO RIGHT HAND COT END.
 3. POSITION EACH COT END WITH THE CAM-BOLTS FACING EACH OTHER. ATTACH THE FIXED SIDE (WITH THE CAP ON TOP) TO THE COT ENDS USING FOUR M6 X 100MM JCB BOLTS. TIGHTEN 2 - 3 TURNS ONLY.
 4. INSERT FOUR M6 X 100MM JCB BOLTS THROUGH HOLES IN LEG AT HEIGHT REQUIRED.
 5. PLACE MATTRESS BASE ON TOP OF BOLTS (**NOTE: THE MATTRESS BASE RAIL TO THE DROP SIDE LEGS HAS TWO CROSS DOWEL PER END RE-DIAGRAM ON LHS**). THIS WILL GIVE YOU A STABLE PLATFORM WHILE YOU PULL OUT EACH BOLT AND REATTACH INTO BASE. (**CARE MUST BE TAKEN TO ENSURE THE BOLT AND CROSS DOWEL IS CORRECTLY ALIGNED BEFORE TIGHTENING, OTHERWISE THREAD DAMAGE MAY OCCUR**). FOR THE DROP SIDE LEGS, INSERT & TIGHTEN THE TOP BOLTS TO THE MATTRESS BASE 2-3 TURNS ONLY.
 6. PLACE DROPSIDE BETWEEN THE TWO ENDS WITH THE CAP ON TOP. (**IMPORTANT: THE SIDE WITH THE EDGE OF THE MOULDING SHOWING SHOULD BE FACING THE INSIDE OF THE COT**). LINE UP THE HEAD OF THE CAM-BOLTS TO THE LOCATING HOLES AT THE TOP OF THE TOP PLASTIC GUIDE, INSERT AND SLIDE UPWARDS.
- (NOTE: KEEP DROPSIDE SQUARE TO ENDS TO PREVENT JAMMING).**
7. LOCATE PINS ON THE BOTTOM OF THE LEG INTO THE GROOVE IN THE BOTTOM PLASTIC GUIDES.

8. ONCE ALL CAMBOLTS AND PINS ARE IN LOCATION, TIGHTEN ALL JCB BOLTS.
9. TAKE THE 60MM BRASS CONNECTOR BOLTS AND CAPS AND PLUG UP THE MATTRESS BASE LOCATION HOLES THAT ARE NOT IN USE.
10. THE DROPSIDE SHOULD OPERATE SMOOTHLY. IF REQUIRED 1 X SPACER (LARGE WASHER) IS SUPPLIED WHICH CAN BE PLACED BETWEEN THE LEG AND BASE OF THE DROPSIDE. SIMPLY UNDO THE JCB BOLT ON EITHER END OF THE DROPSIDE, FIT SPACER BETWEEN THE BASE AND LEG, REFIT JCB BOLT ACCORDINGLY.

RECOMMENDED MATTRESS SIZE

THIS COT HAS BEEN MANUFACTURED FOR USE WITH A MATTRESS, WHICH MEASURES 690MM BY 1300MM LONG, **AND 100MM TO 150MM (MAXIMUM) THICKNESS.** THE WIDTH AND LENGTH ARE SPECIFIED BECAUSE IT IS IMPORTANT THAT THE GAPS BETWEEN THE MATTRESS AND THE SIDES AND ENDS OF THE COT WILL NOT EXCEED 40MM WHEN THE MATTRESS IS PUSH TO ONE SIDE OR END OF THE COT. THIS IS TO MINIMISE THE RISK OF A CHILD'S LIMB BECOMING CAUGHT IN THE GAP. THE THICKNESS HAS BEEN SPECIFIED TO ENSURE THAT THE DEPTH OF THE COT IS GREATER THAN 500MM WITH THE MATTRESS BASE IN THE LOWER POSITION TO MINIMISE THE RISK OF A CHILD CLIMBING OR FALLING OUT OF THE COT.

OPERATING INSTRUCTIONS

WHEN THE DROPSIDE IS IN THE DOWN POSITION, TO RAISE, LIFT THE DROPSIDE WITH A SWIFT ACTION SO THERE WILL BE ENOUGH MOMENTUM TO DEFLECT THE SPRINGS AND ENGAGE AT THE HIGHER POSITION. TO LOWER DROPSIDE, **LIFT THE DROPSIDE UP ABOUT 20MM**, THEN APPLY PRESSURE WITH SIDE OF YOUR LEG TO MIDDLE OF THE BOTTOM RAIL OF THE DROPSIDE, AND NOW YOU CAN LOWER THE DROPSIDE TO ITS LOW POSITION.

MAINTENANCE (IMPORTANT)

FROM TIME TO TIME, CHECK SCREWS AND BOLTS AND RE-TIGHTEN IF REQUIRED. FOR CLEANING, WIPE WITH SOFT DAMP CLOTH. USE MILD SOAPY SOLUTION IF NECESSARY.

WARNING

TO PREVENT FALLS THE MATTRESS BASE OF THIS COT SHOULD BE ADJUSTED TO THE LOWEST POSITION BEFORE THE CHILD CAN SIT UP. SIMPLY REMOVE THE JCB BOLTS HOLDING THE MATTRESS BASE TO THE LEGS AND REFIT THEM IN THE LOWEST SET OF HOLES. ENSURE THE COT IS PLACED AT A REASONABLE DISTANCE FROM CURTAINS, BLINDS, HEATERS AND POWER POINTS, AND TO KEEP MEDICATION, STRING, ELASTIC, SMALL TOYS OR SMALL ITEMS SUCH AS MONEY OUT OF REACH FROM ANY POSITION IN THE COT.

MANUFACTURED BY:

GENESIS FURNITURE

1 / 43 HOBILL AVENUE, MANUKAU CITY

P.O.BOX 97 205

MANUKAU CITY

AUCKLAND

NEW ZEALAND

PH/FAX: (09) 263 5142

E-mail- info@genesisfurniture.co.nz

www.genesisfurniture.co.nz

CANTERBURY

COT

Mark 2

by

The logo for Genesis Furniture features the word "genesis" in a bold, lowercase, sans-serif font. A teal swoosh underline is positioned above the letters "e", "n", and "i". Below the brand name, the tagline "FURNITURE FOR NEW BEGINNINGS" is written in a smaller, teal, uppercase font.

FURNITURE FOR NEW BEGINNINGS

AFRDI Test No: 5199/2