

Cleaning the Car Seat

The cover and accessories are removable for cleaning.

Refer to sewn in labels for fabric care instructions.

Plastic and metal parts may be sponged lightly using warm water and a mild detergent.

Dry thoroughly before storing. Clean the harness in the same way and allow to dry.

Dirt may find its way into the buckle mechanism, which may stop it working properly.

Clean with a dry brush initially and then warm water until clean.

Never clean any part of this product with abrasive based, ammonia based or spirit type cleaners.



Plum Travel System

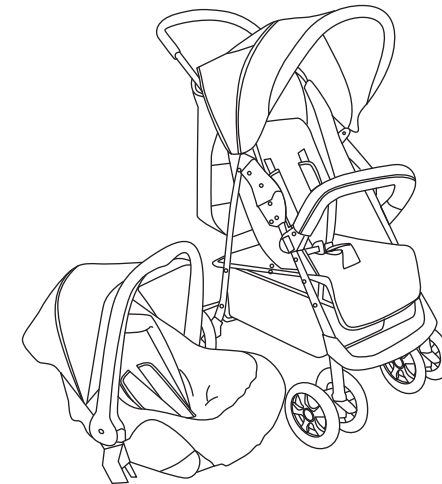









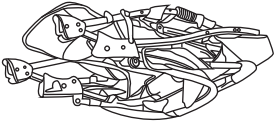

**IMPORTANT:
RETAIN FOR FUTURE REFERENCE
READ CAREFULLY**

▽
Specification of product

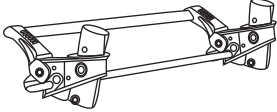
Age	0 Months+
Load capacity	Under 15 kgs
No. of passenger	1 person
Weight	Approx. 10.5 kgs
Assembled Size	92.5(L)cm x 53(W)cm x 104(H)cm

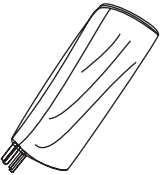

Parts

<p>A x1</p> 	<p>B x1</p> 	<p>C x2</p> 
<p>D x2</p> 	<p>E x1</p> 	<p>F x2 Metal Washer</p> 
<p>G x2 Plastic Eye Splice</p> 	<p>H x2 Plastic Cap</p> 	<p>I x2 Round Cap</p> 
<p>J x1</p> 	<p>K x1</p> 	

Care

Pushchair Maintenance

This product requires regular maintenance to ensure correct and safe performance. Regularly inspect the wheels, locks, brakes, harness, catches, seat adjusters, joints and fixings to ensure they are clean, secure and in full working order.

Replace tyres if they are excessively worn.

If parts become stiff or difficult to operate, ensure dirt is not the cause, then try a light application of a silicon lubricant, ensuring it penetrates between the components.

Regular lubrication of moving parts will extend the life of your product and make opening and folding easier.

After exposure to damp conditions, dry off with a soft cloth and leave fully open in a warm environment. Storing damp will encourage mildew to form. Store in a dry place.

Do not leave in sunlight for prolonged periods as some fabrics may fade.

Do not store the raincover where it may be exposed to heat as this may cause distortion.

Car Seat Maintenance

This product requires regular maintenance to ensure correct and safe performance.

Regularly inspect the harness, handle, seat belt guides and locking mechanisms to ensure that they are undamaged and in full working order.

After exposure to damp conditions, dry off with a soft cloth and leave in a warm environment. Storing damp will encourage mildew to form. Store in a dry place.

Do not leave in sunlight for prolonged periods as some fabrics may fade.

Do not let the car seat come into contact with corrosive substances e.g. battery acid.

Cleaning the Pushchair

Plastic and metal parts may be sponged lightly using warm water and a mild detergent.

Dry thoroughly before storing.

Refer to sewn in labels for fabric care instructions.

Never clean any part of the product with abrasive, ammonia based, bleach based or spirit type cleaners.

The raincover can be cleaned with warm water and a mild detergent.

Car Seat Safety

- Do not use any load-bearing contact points other than those described in the instructions and marked on the restraint system.
- Do not place the infant car seat on high surfaces, such as tables, worktops, beds etc. due to risk of falling.
- It is recommended that your infant car seat is replaced following an accident.
- Damage that is not visible may reduce the protection that it offers.
- We strongly advise that infant car seats are never bought second-hand as they can have damage that is not visible that could affect the safety performance.
- It is advisable not to use car seats longer than 5 years after the date of purchase. Plastics and other materials may deteriorate due to the natural aging process.

Assembly

1. Release the pushchair (A) from the locked position by lifting the locking catch from over the locking rivet on the pushchair frame.

Note. You may have to squeeze the pushchair legs and handles together first so as to release the tension on the rivet.

Standing behind the pushchair and holding it by the handle, lift the handle upwards to unfold the pushchair frame.

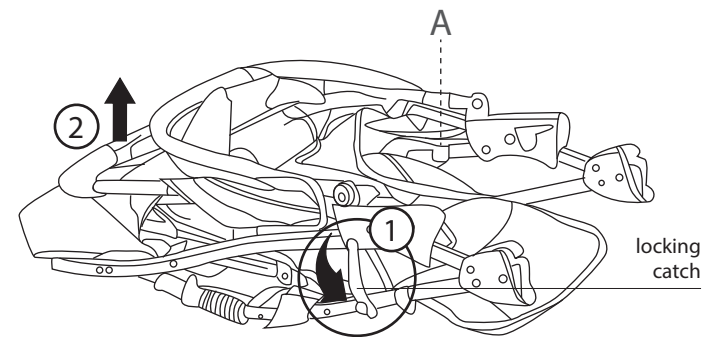

2a. To assemble the rear wheels, place one metal washer (F) onto the end of the rear axle (E). Then place one wheel (C). Attach one plastic eye splice (G), then one plastic cap (H) and finally one round cap (I). Repeat for the other side.

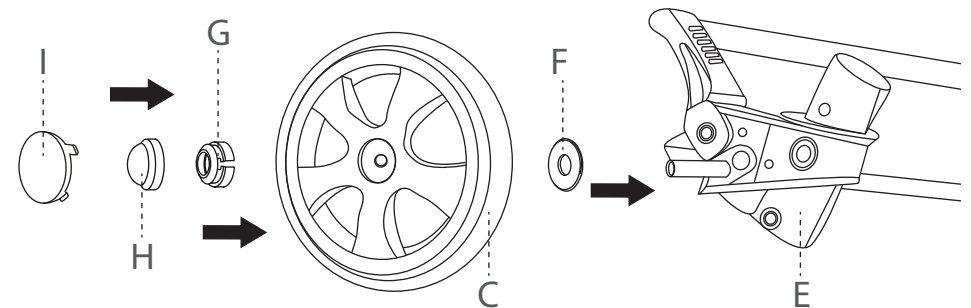

Assembly

2b. Fit the assembled rear wheel axle to the pushchair frame. Insert the ends of tubing into the housing located on the assembled rear wheel axle. Push upward until you hear it lock and click into position.

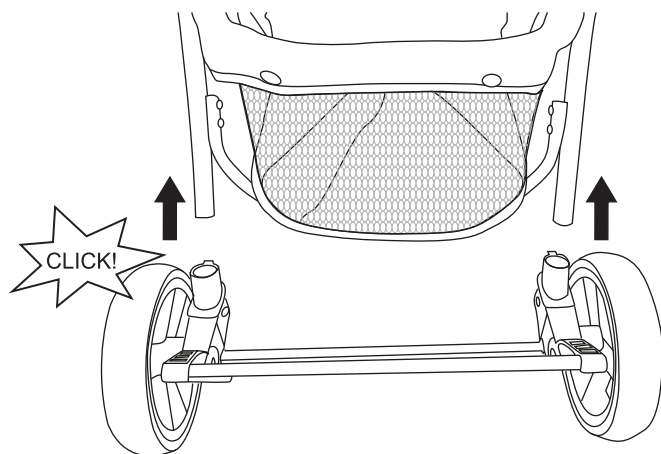

3. To attach the front swivel wheels (D), insert wheel housing onto the front leg and push upward until you hear it lock into position. Repeat for other leg.

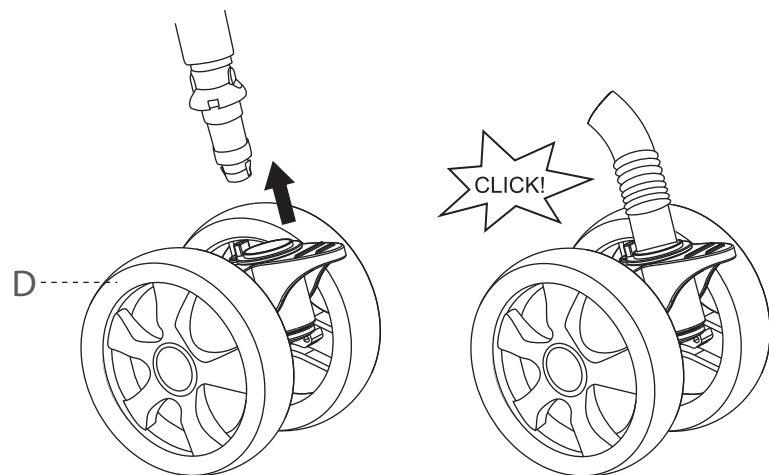

Car Seat Safety

Group 0+ Infant Carrier.

Suitable for infants from birth to 13kg (approximately 12-15 months).

Before use check that the child restraint is compatible for use in your car.

For use as part of the Plum travel system. Do not use with other pushchairs.

NOTICE

This is a 'Universal' child restraint. It is approved to Regulation No. 44.04 series of amendments, for general use in vehicles and it will fit most, but not all car seats. A correct fit is likely if the vehicle manufacturer has declared in the vehicle handbook that the vehicle is capable of accepting a 'Universal' child restraint for this age group. This child restraint has been classified as 'Universal' under more stringent conditions than those which applied to earlier designs which do not carry this notice. Only suitable for use in approved vehicles fitted with 3 point retractor safety belts, approved to UN/ECE Regulation NO.16 or other equivalent standard.

⚠ WARNING!

- Never leave your child unattended in the seat, either in or out of the car.
- Never place your child in the seat without securing them with the harness.
- Only install this car seat facing in the front or rear passenger seat of the car.
- Do not use on rear and side facing vehicle seats.
- Do not place this rear facing child seat on a front seat with an airbag. Death or serious injury can occur.
- Check the the adult seat belt is threaded correctly and tight.
- This car seat must not be used if the adult seat belt is too high.
- Ensure that your child is correctly secured; the harness must be adjusted to their body and not twisted.
- Do not make alterations to the product as this could affect the overall safety of the seat.
- Ensure that all luggage and objects liable to cause injury in the event of an accident are properly secured.
- The cover is an integral part of the car seat. Never use the car seat without the cover. Do not replace the seat cover with anything other than one supplied by the manufacturer.
- Rigid items and plastic parts of the car seat must be positioned and installed so that they do not under normal everyday use of the vehicle, become trapped by a moveable seat or in a door of the vehicle.

Safety

This vehicle is intended for one child from birth (0 months) and up to a maximum weight of 15kg.

This product complies with EN 1888:2012.

⚠️ WARNING!

- Never leave your child unattended.
- Ensure that all locking devices are engaged before use.
- To avoid injury ensure that your child is kept away when unfolding and folding this product.
- Do not let your child play with this product.
- Always use the restraint system. Ensure it is correctly fitted at all times.
- Check that the pushchair body or seat unit attachment devices are correctly engaged before use.
- This product is not suitable for running or skating.
- Use the most reclined position for new born babies.
- Ensure the parking brake is engaged during the loading and unloading of your child.
- The basket can carry a maximum of 2kg.
- Any load attached to the handle and/ or on the back of the backrest and/ or on the sides will affect the stability of the product.
- Do not overload the product.
- Do not use this product if any part is broken, torn or missing.
- Do not use replacement parts or accessories which are not approved by the manufacturer.
- Always apply the parking brake when the pushchair is stationary.
- Never leave a raincover, hood or apron on the product indoors, in a hot atmosphere or near a heat source, as your child may overheat.
- Take care when going up or down kerbs.
- Take extra care in windy conditions.
- Remove your child and fold the pushchair when going up or down stairs or escalators.
- To prevent damage, remove the raincover before folding the pushchair.
- Do not place anything on top of the raincover.
- Avoid placing the pushchair near naked heat sources such as electric bar fires, gas fires etc. or where a child could gain access to any other kind of hazards.
- The hood pocket can carry a maximum of 0.5kg.

Assembly

4. Attach the bumper bar (B) to the front of the pushchair frame. Attach the bumper bar connector posts to the frame sides. Push in the locking clip to secure. Repeat for both sides of the bumper bar.

To remove bumper bar, lift up the locking clip and pull bumper bar away from the pushchair frame. Ensure both clips are unlocked before removing bumper bar.

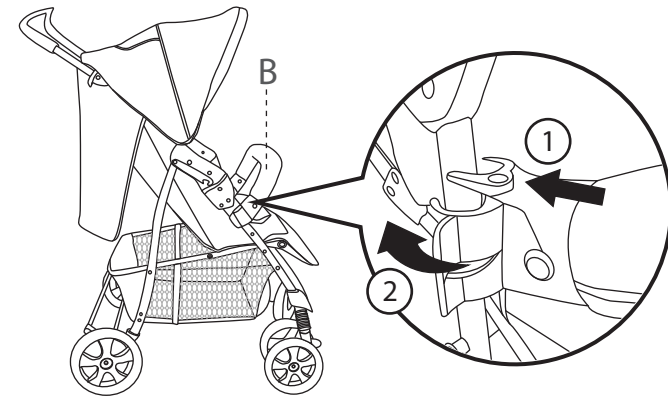

Canopy Adjustment

The canopy can be opened or closed by pulling or pushing on the canopy rim. There is also a viewing window located at the top of the canopy and a pocket at the rear of the canopy.

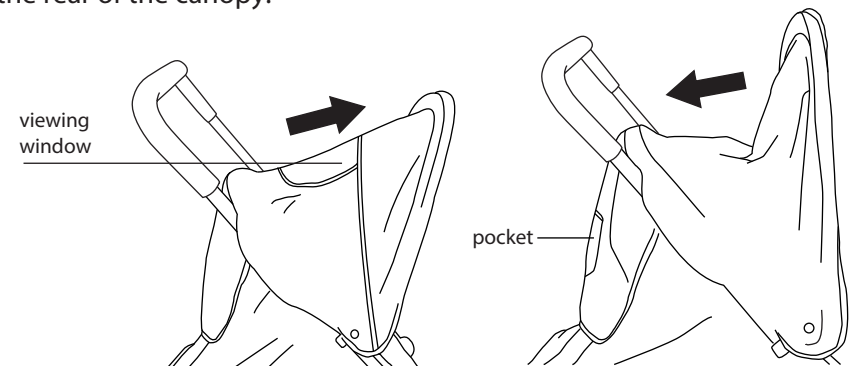

Footrest Adjustment

Press on each adjuster in turn while simultaneously pressing down or pulling up lightly on the footrest.

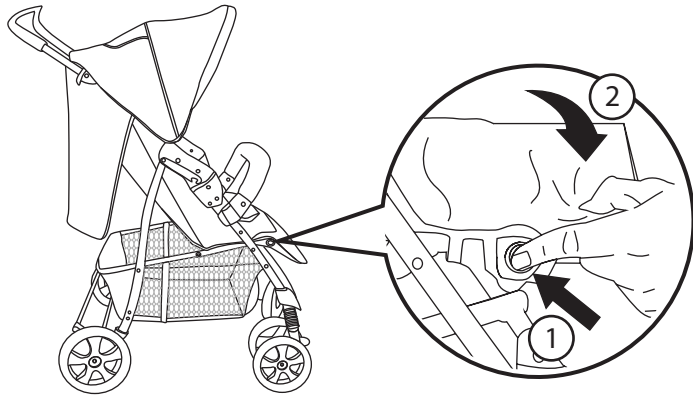

Brakes

To engage the brake push down the brake locking bar. Lift up bar to release brake.

WARNING! Always engage wheel brakes when the stroller is not moving.

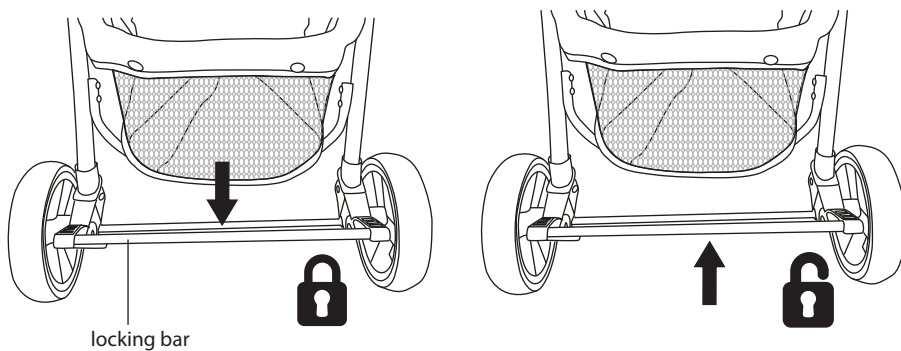

Car Seat Cover

WARNING! You must never use the car seat without the manufacturer's cover. It is an important safety feature of the car seat.

1. To remove the cover, first open the harness buckle and remove the chest pads and crotch pad.
 2. The car seat comes with a head support designed to give extra protection and support for your baby's head. Thread the harness through the cutouts to remove the head support.
 3. To remove the cover, detach the clips located at the side of the car seat - two either side. Pull up the cover over the sides of the car seat. Slide the harness and buckle through the cutouts and remove the cover.
- Note. the canopy is not removable.

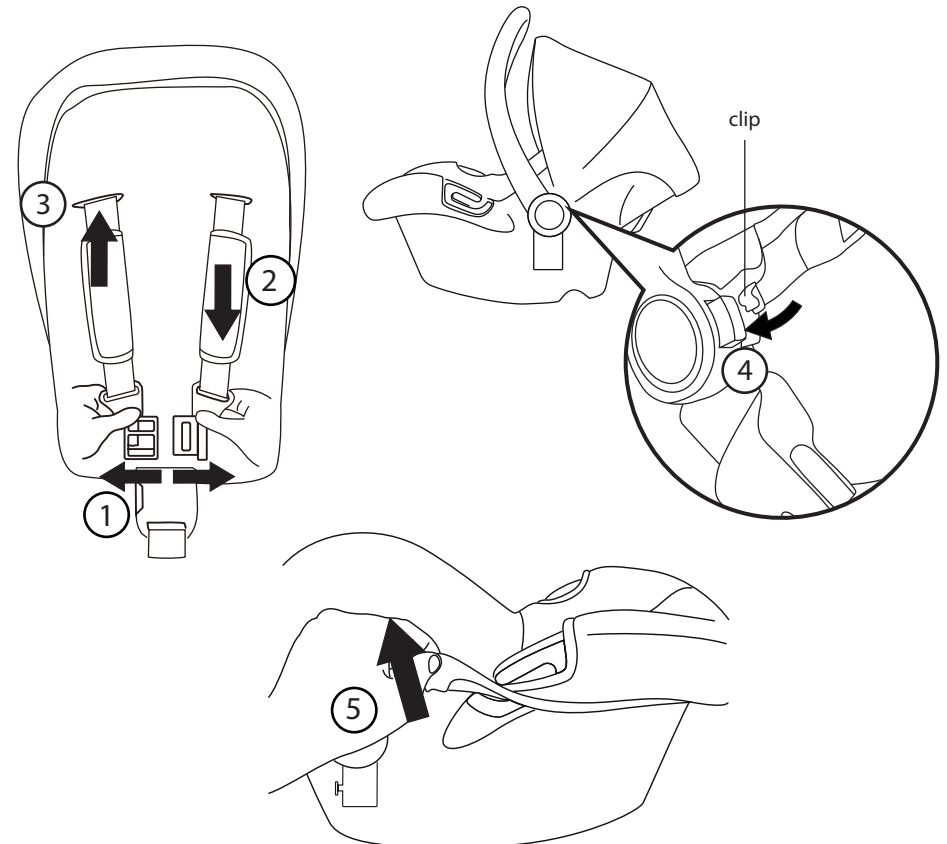

Car Seat Vehicle Installation

VERY IMPORTANT. Not all car seats fit all cars. Before you buy, ensure that it fits correctly and is suitable for your child.

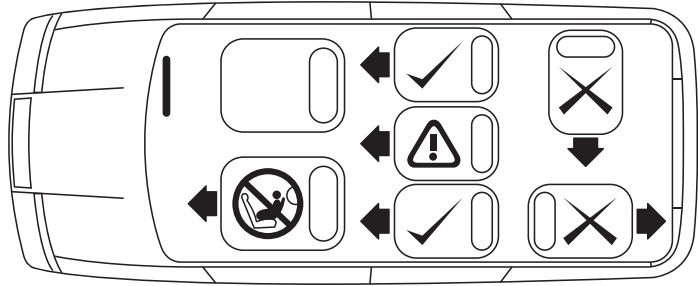

WARNING! DO NOT place this car seat on vehicle seats with front airbags.
WARNING! This baby car seat can only be installed using a 3-point vehicle seat belt. You must never fit the car seat with a 2-point lap belt.
WARNING! The car seat must always be rearward facing (with your baby facing the back of the vehicle).

Car Seat Manual Storage

It is very important to keep manual for future reference. To store instruction manual with your car seat, pull up the seat cover and insert manual for safe keeping.

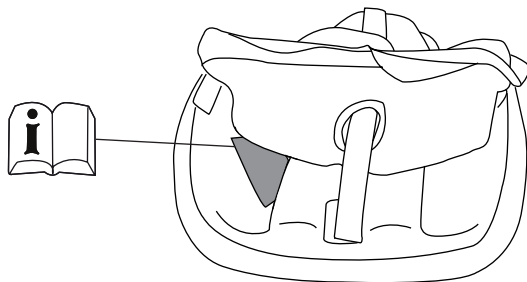

Swivel Wheels

Your stroller has lockable front swivel wheels. To lock swivel wheels press the pedal down. Repeat on both wheels. Push up to release and make stroller go straight.

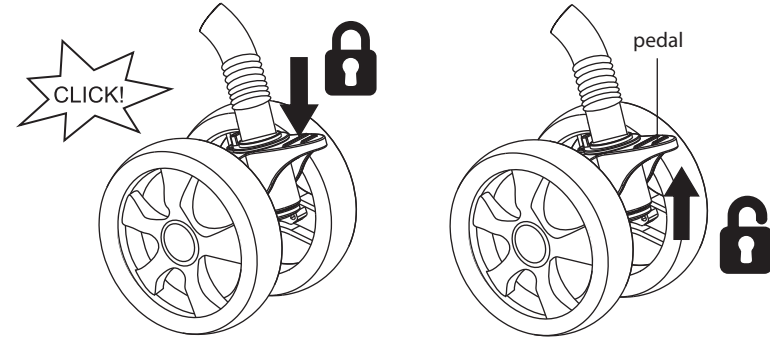

Backrest Adjustment

Locate the backrest adjustment mechanism at the rear of the seat. Squeeze the clip on the reclining harness and gently lower the backrest. To raise the backrest, squeeze the clip on the reclining harness and gently pull up the backrest to the desired height.
WARNING! Always ensure that the seat is securely fixed in position before use.

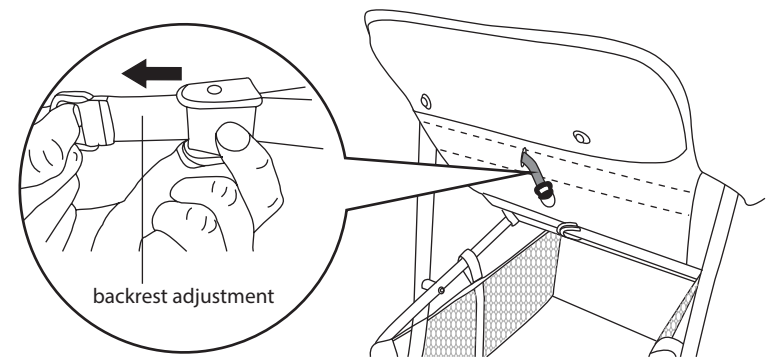

Harness Operation

A five-point safety harness is provided to restrain your child and should always be worn. To fasten, push the side clips (a) into the centre buckle (b). Sliding adjusters (c) are fitted and should be adjusted to suit your child.

To release, press the side clips at points (d) and remove from buckle.

WARNING! Always use the harness and ensure it is correctly and securely fitted while child is in the seat.

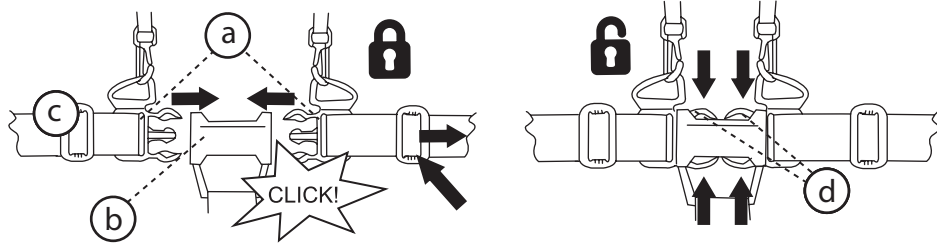

Folding

Lock swivel wheels and engage the brake. Pull both fold release triggers towards you. Push the handle downwards gently and lower the pushchair downwards. Engage the locking catch.

Note. Remove all items from the basket before attempting to fold.

Note. If using with car seat, ensure it has been removed before folding.

WARNING! Always fold your canopy before folding your pushchair.

WARNING! Due care should be taken when folding & unfolding pushchair.

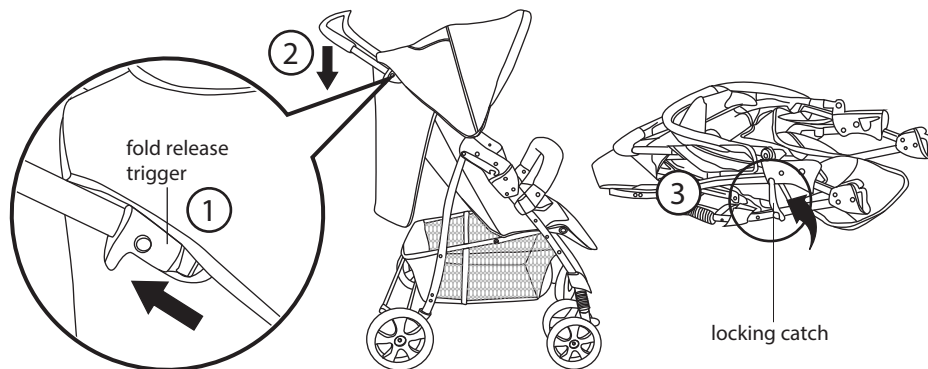

Car Seat Vehicle Installation

3. Pull the diagonal section of the seat belt around the back of the car seat. Place the diagonal section of the seat belt securely into the belt guide located on the back of the car seat.

Holding the car seat firmly, pull the diagonal section of the seat belt to remove any slack.

Check that the angle of the car seat back rest is not too upright and make sure the seat belt is not twisted. Push firmly on the back of the car seat. It should feel tight and secure. There should be no excessive movement forward or to the side.

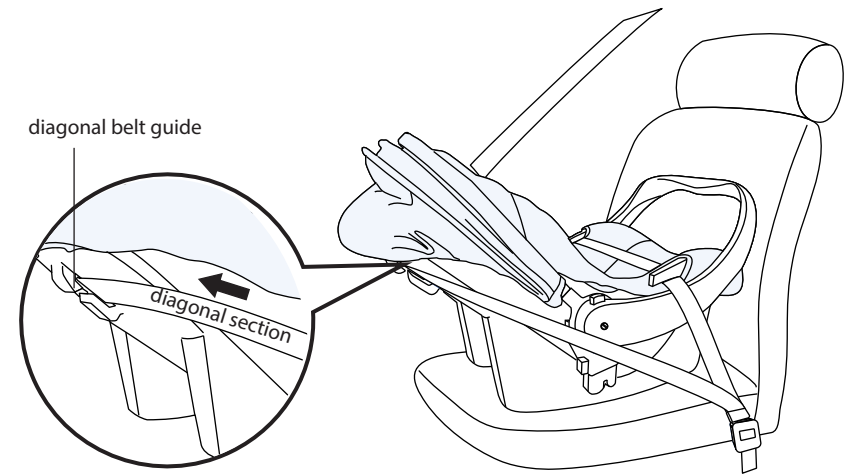

4. To remove the car seat from the vehicle, remove the diagonal section of the seat belt from the diagonal belt guide. Unfasten the seat belt and remove the belt out of the lap belt guide taking care to hold the seat belt away from your baby. Adjust the car seat handle to position B* See page 12. Carefully remove the car seat from the vehicle using the carry handle.

WARNING! Ensure the handle has clicked into the correct position before lifting.

Car Seat Vehicle Installation

WARNING! Never use the car seat on a passenger seat fitted with a front airbag. It is VERY DANGEROUS AND ILLEGAL.

WARNING! The car seat must always be fitted using a 3 point lap and diagonal seat belt.

1. Adjust the car seat handle to position A * See page 12. Place the car seat on the vehicle seat with your baby facing the back of the vehicle.

WARNING! The car seat must ALWAYS be rearward facing with your baby facing the back of the vehicle.

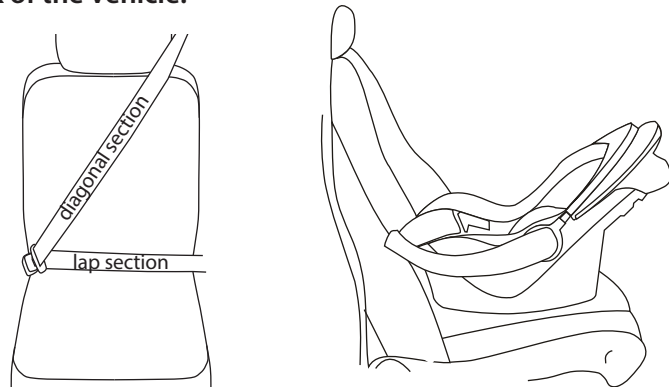

2. Slowly pull the seat belt out across the car seat and fasten the seat belt. Pass the lap section of the seat belt through both lap belt guides.

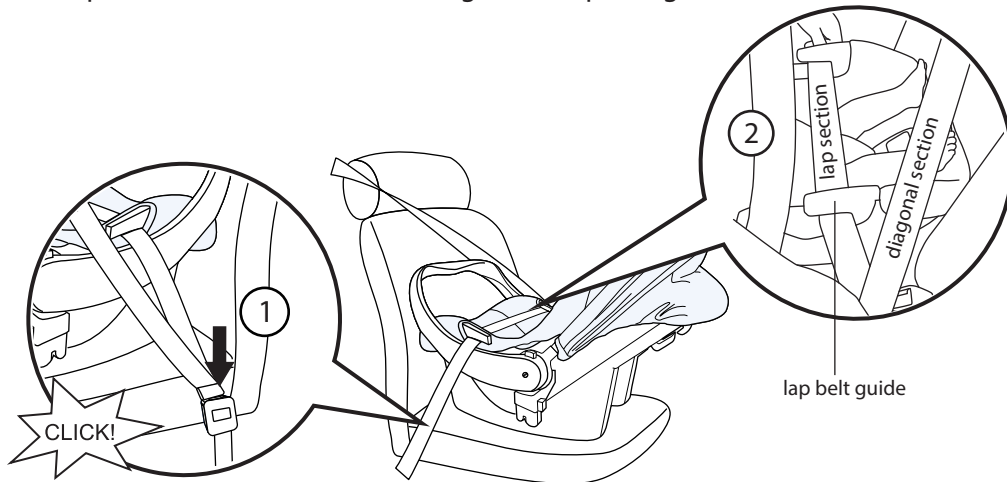

Travel System

1. The car seat (K) can be fitted to the pushchair to create a travel system.

Adjust the pushchair backrest to the fully reclined position (4). Fold the canopy.

2. Lower the car seat onto the pushchair. Attach the connectors located both sides of the car seat to the frame. Ensure the car seat clicks into place.

Lift the car seat gently by the handle to check the car seat has locked into place.

3. Adjust the car seat handle to position (C) *See page 12.

WARNING! Ensure the car seat base aligns with the bumper bar before use.

WARNING! Check the car seat connectors are correctly engaged before use.

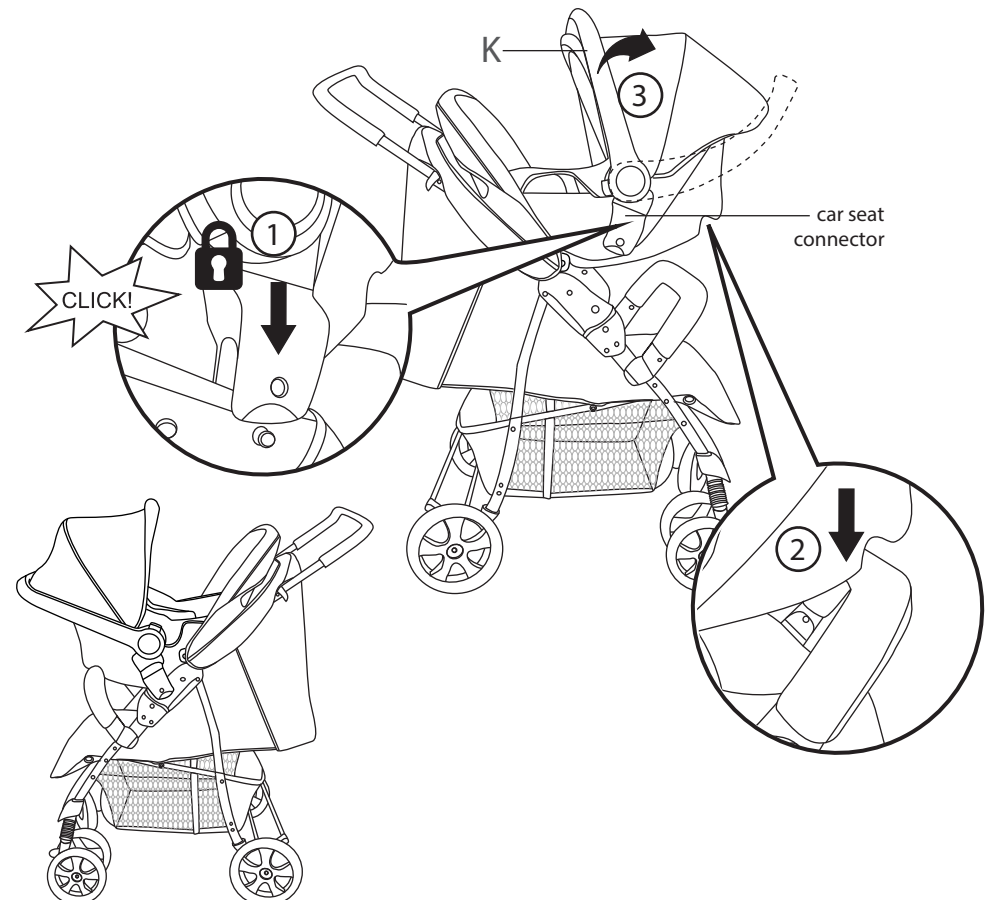

Detaching Car Seat

1. Rotate the car seat handle to the carrying position (B) * See page 12.
2. Pull out the car seat connector from the pushchair frame to release the connector from the holding pin. Repeat for both sides of the pushchair.
3. Lift the car seat away from the pushchair frame.

WARNING! Your car seat should always be rearward facing.

WARNING! The car seat does not replace a cot or bed. Should your child need to sleep then it should be placed in a suitable pram body or cot.

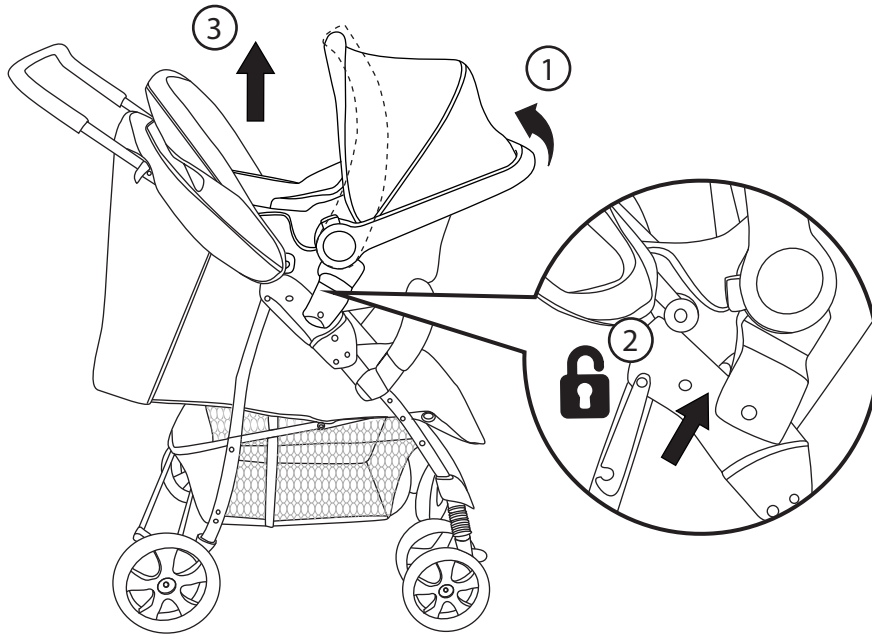

WARNING! The car seat is compatible with the Plum pushchair only.
WARNING! The Plum pushchair is compatible with the included car seat only.

Car Seat Harness

5. Place the shoulder straps over the sides of the car seat. Carefully place your baby in the car seat and check that the shoulder straps are in the correct position for your baby's shoulders *See page 13.

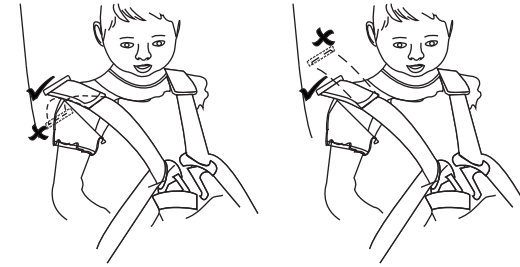

6. Correctly position the 5-point harness over the baby making sure there are no twists. Fit the shoulder harness fasteners together and then push firmly into the buckle housing until you hear a click. Pull both shoulder & waist straps towards you to remove any slack. Tighten the harness straps by pulling the harness adjuster strap until the baby is secure.

WARNING! Your child must be fastened in the safety harness at all times when using the car seat.

WARNING! You should only be able to insert 2 fingers between the shoulder straps and the waist straps.

To remove your child from the car seat, slacken the shoulder straps. Unfasten the harness and place shoulder straps over the side of the car seat.

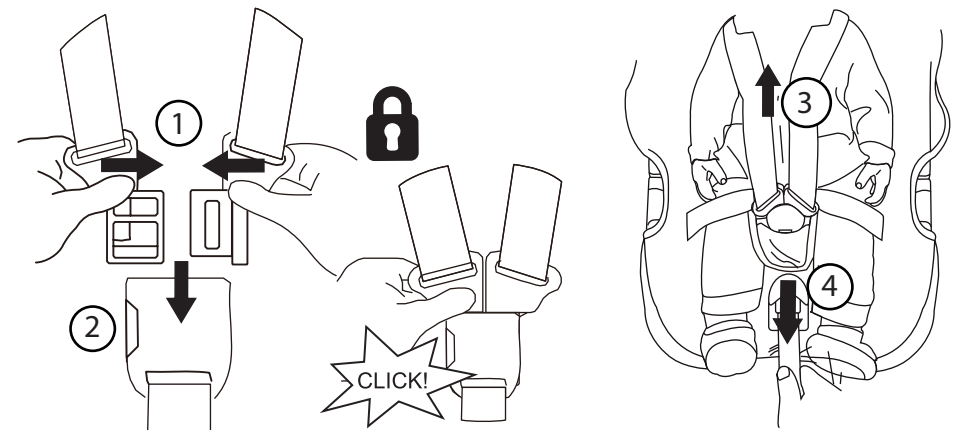

Car Seat Harness

3. Once the desired shoulder position has been fitted pull the end part of the harness to tighten the shoulder harness.

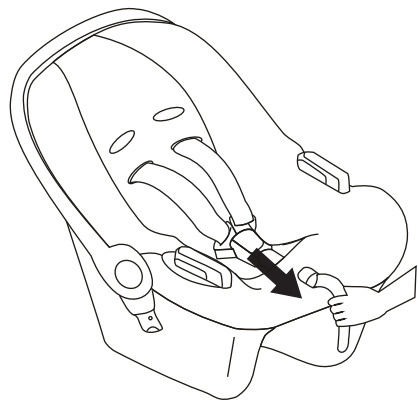

4. If required, re-adjust the harness slack * See page 13. Step 1. Press the fastening harness button located on the side of the buckle housing to open. Pull the shoulder harness fasteners apart.

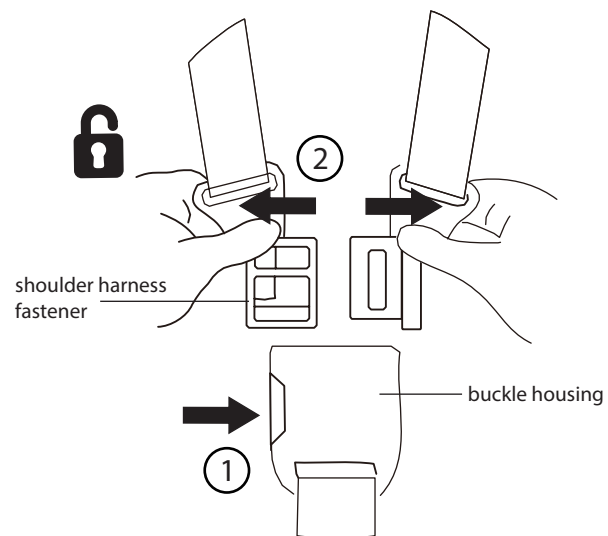

Raincover

Place the raincover (J) over the canopy front. Fasten the velcro straps around the front legs (a), handle bars (b) and canopy (c) to secure.

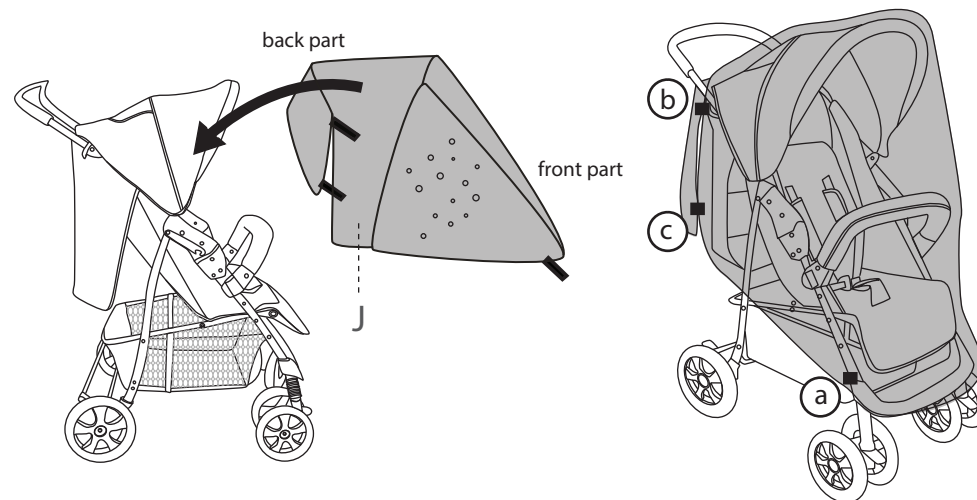

The raincover also fits in travel system mode - when the car seat is fitted to the pushchair frame. Secure with velcro tabs.

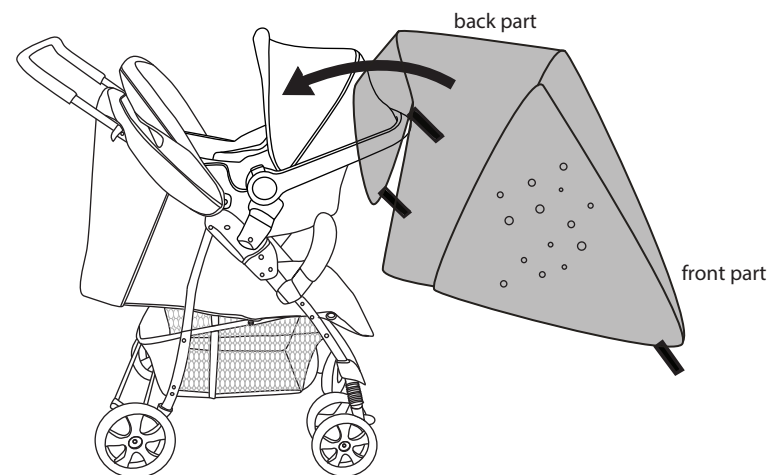

Car Seat Handle Adjustment

The car seat (K) has four handle positions.

WARNING! Make sure that you understand the different handle positions and can correctly adjust the handle to the required position.

To adjust handle position, push in and hold both handle release triggers located on the sides of the handle. Move the handle to the required position and make sure that both sides click into position.

- A. In car position
- B. Carrying & rocking position
- C. Travel system mode & helps access in and out
- D. Stable position

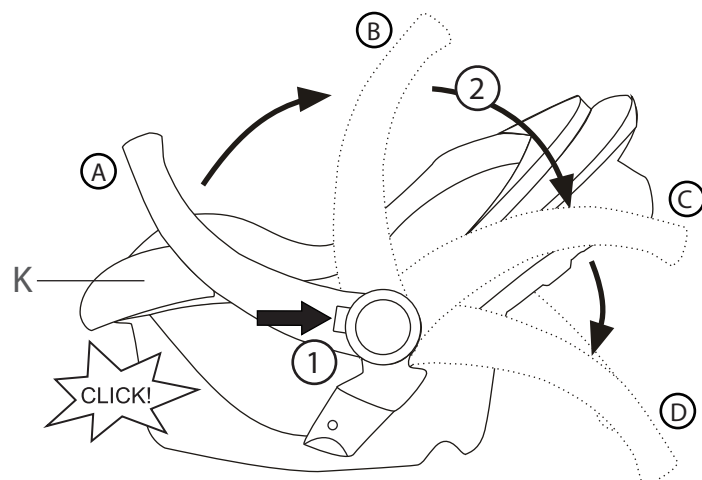

Car Seat Harness

Before you install the car seat into a vehicle it is very important that you make sure the shoulder straps are at the correct height for your baby. The shoulder straps should be level or just below your baby's shoulders.

1. Place the car seat on a level floor surface. Slacken the shoulder straps by pressing the harness release button. At the same time, pulling both shoulder straps forward. **Note. the button may be hidden by the seat cover.**

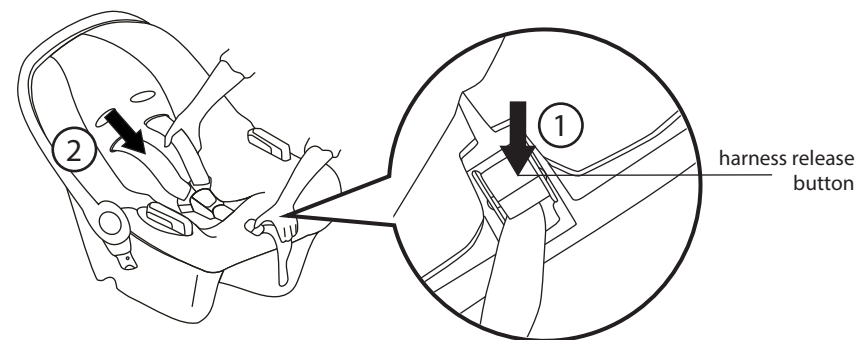

2. Ensure the shoulder harness is adjusted to the correct position for your baby. To adjust, open the harness buckle * See page 14. and thread the harness through the shoulder harness routing. Once desired height is chosen, thread the harness back through the harness routing.

WARNING! Ensure both of the shoulder straps go through harness routing at the same height and the harness does not twist.

